



US012420864B2

(12) **United States Patent**
Gordon

(10) **Patent No.:** **US 12,420,864 B2**

(45) **Date of Patent:** **Sep. 23, 2025**

(54) **LEADING-EDGE STEERING ASSEMBLY**

(71) Applicant: **Robby Gordon**, Charlotte, NC (US)

(72) Inventor: **Robby Gordon**, Charlotte, NC (US)

(*) Notice: Subject to any disclaimer, the term of this patent is extended or adjusted under 35 U.S.C. 154(b) by 0 days.

(21) Appl. No.: **18/106,383**

(22) Filed: **Feb. 6, 2023**

(65) **Prior Publication Data**

US 2023/0182812 A1 Jun. 15, 2023

Related U.S. Application Data

(63) Continuation of application No. 17/188,636, filed on Mar. 1, 2021, now Pat. No. 11,584,435, which is a
(Continued)

(51) **Int. Cl.**

B62D 7/16 (2006.01)

B60B 3/06 (2006.01)

(Continued)

(52) **U.S. Cl.**

CPC **B62D 7/22** (2013.01); **B60B 3/06**
(2013.01); **B60B 3/16** (2013.01); **B60B**
27/0052 (2013.01);

(Continued)

(58) **Field of Classification Search**

CPC B60G 3/20; B60G 7/005; B60G 7/001;
B60G 7/008; B62D 7/16; F16C 11/06
See application file for complete search history.

(56) **References Cited**

U.S. PATENT DOCUMENTS

2,753,225 A * 7/1956 Gilmer, III F16C 11/0614
384/207

3,383,129 A * 5/1968 Ulderup F16C 11/0676
403/139

(Continued)

FOREIGN PATENT DOCUMENTS

DE 2451182 A1 * 10/1975 F16B 33/06

OTHER PUBLICATIONS

Chassis Frame With Variable Assembly Interface, May 7, 1975, EPO, DE 2451182 A1, Machine Translation of Description (Year: 1975).*

Primary Examiner — Timothy Wilhelm

Assistant Examiner — Matthew D Lee

(74) *Attorney, Agent, or Firm* — Barry Choobin; Patent 360

(57) **ABSTRACT**

A leading-edge steering system is provided for a front suspension of an off-road vehicle. The leading-edge steering system is comprised of a spindle assembly that supports a drive axle assembly to conduct torque from a transaxle to a front wheel. A first rod-end joint pivotally couples an upper suspension arm and the spindle assembly, and a second rod-end joint pivotally couples a lower suspension arm and the spindle assembly. A steering rod-end joint pivotally couples a first end of a steering rod with a leading-edge portion of the spindle assembly. A steering gear is coupled with a second end of the steering rod and configured to move the steering rod, such that the spindle assembly rotates with respect to the upper and lower suspension arms. The leading-edge portion is configured to exert primarily tensile forces on the steering rod during travel over rough terrain.

10 Claims, 6 Drawing Sheets

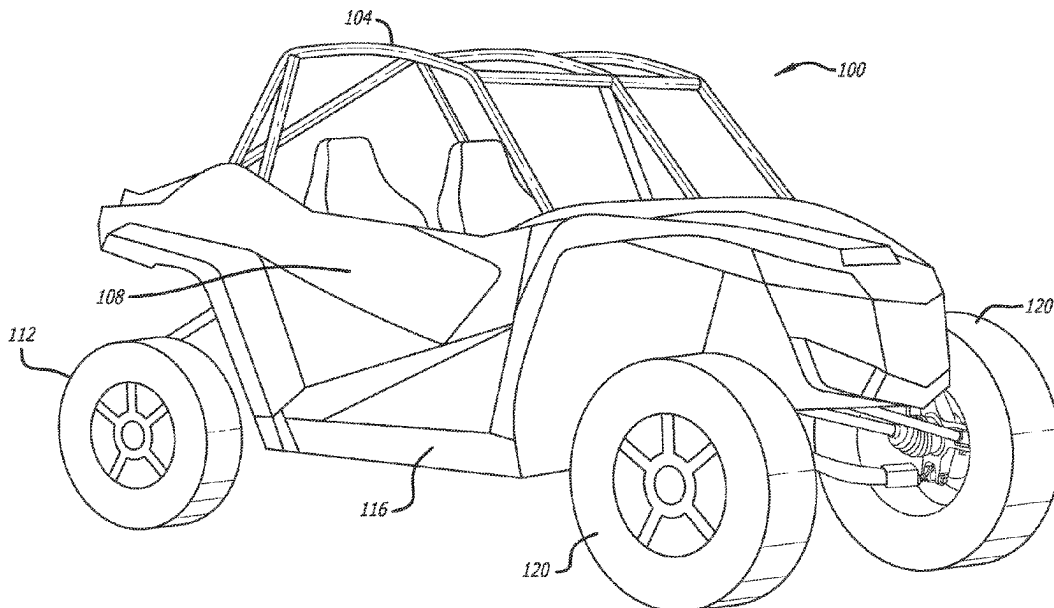

Related U.S. Application Data

continuation of application No. 16/422,180, filed on May 24, 2019, now Pat. No. 10,940,886, which is a continuation of application No. 15/625,813, filed on Jun. 16, 2017, now Pat. No. 10,414,434.

(60) Provisional application No. 62/480,960, filed on Apr. 3, 2017.

(51) **Int. Cl.**

- B60B 3/16** (2006.01)
- B60B 27/00** (2006.01)
- B60B 35/12** (2006.01)
- B60G 3/14** (2006.01)
- B60G 3/20** (2006.01)
- B60G 7/00** (2006.01)
- B60G 7/02** (2006.01)
- B60G 15/06** (2006.01)
- B60G 17/00** (2006.01)
- B60K 17/16** (2006.01)
- B60K 17/30** (2006.01)
- B60R 19/54** (2006.01)
- B62D 3/02** (2006.01)
- B62D 7/18** (2006.01)
- B62D 7/20** (2006.01)
- B62D 7/22** (2006.01)
- B62D 21/11** (2006.01)
- B62D 21/12** (2006.01)
- B62D 23/00** (2006.01)
- B62D 25/08** (2006.01)
- B62D 27/02** (2006.01)
- B62D 63/02** (2006.01)
- B62D 65/04** (2006.01)
- F16C 7/02** (2006.01)
- F16C 11/06** (2006.01)
- F16D 3/30** (2006.01)
- F16D 1/10** (2006.01)

(52) **U.S. Cl.**

CPC **B60B 35/128** (2013.01); **B60G 3/14** (2013.01); **B60G 3/20** (2013.01); **B60G 3/202** (2013.01); **B60G 7/001** (2013.01); **B60G 7/005** (2013.01); **B60G 7/008** (2013.01); **B60G 7/02** (2013.01); **B60G 15/063** (2013.01); **B60G 17/00** (2013.01); **B60K 17/16**

(2013.01); **B60K 17/306** (2013.01); **B60R 19/54** (2013.01); **B62D 3/02** (2013.01); **B62D 7/16** (2013.01); **B62D 7/166** (2013.01); **B62D 7/18** (2013.01); **B62D 7/20** (2013.01); **B62D 21/11** (2013.01); **B62D 21/12** (2013.01); **B62D 23/005** (2013.01); **B62D 25/08** (2013.01); **B62D 27/023** (2013.01); **B62D 63/025** (2013.01); **B62D 65/04** (2013.01); **F16C 7/02** (2013.01); **F16C 11/0695** (2013.01); **F16D 3/30** (2013.01); **B60G 2200/14** (2013.01); **B60G 2200/144** (2013.01); **B60G 2200/156** (2013.01); **B60G 2200/44** (2013.01); **B60G 2202/312** (2013.01); **B60G 2204/129** (2013.01); **B60G 2204/143** (2013.01); **B60G 2204/148** (2013.01); **B60G 2204/30** (2013.01); **B60G 2204/416** (2013.01); **B60G 2204/62** (2013.01); **B60G 2206/11** (2013.01); **B60G 2206/12** (2013.01); **B60G 2206/50** (2013.01); **B60G 2206/72** (2013.01); **B60G 2206/73** (2013.01); **B60G 2206/84** (2013.01); **B60G 2300/07** (2013.01); **F16C 2326/24** (2013.01); **F16D 2001/103** (2013.01)

(56)

References Cited

U.S. PATENT DOCUMENTS

5,259,200	A *	11/1993	Kamody	C21D 6/04 148/578
6,924,036	B2 *	8/2005	Polastri	C08L 27/18 428/457
2004/0066015	A1 *	4/2004	Kilburn	B60G 7/005 280/124.135
2005/0047851	A1 *	3/2005	Molenaar	F16C 11/0628 403/122
2005/0247502	A1 *	11/2005	Ziech	B62D 7/18 280/93.512
2012/0241237	A1 *	9/2012	Holroyd	B62D 23/005 180/291
2012/0306177	A1 *	12/2012	Thill	B60G 7/001 280/124.152
2013/0199332	A1 *	8/2013	Powell	F16F 1/393 403/164
2015/0251512	A1 *	9/2015	Karpman	F16C 11/0614 29/898.04
2018/0056748	A1 *	3/2018	Grimes	B60G 9/00

* cited by examiner

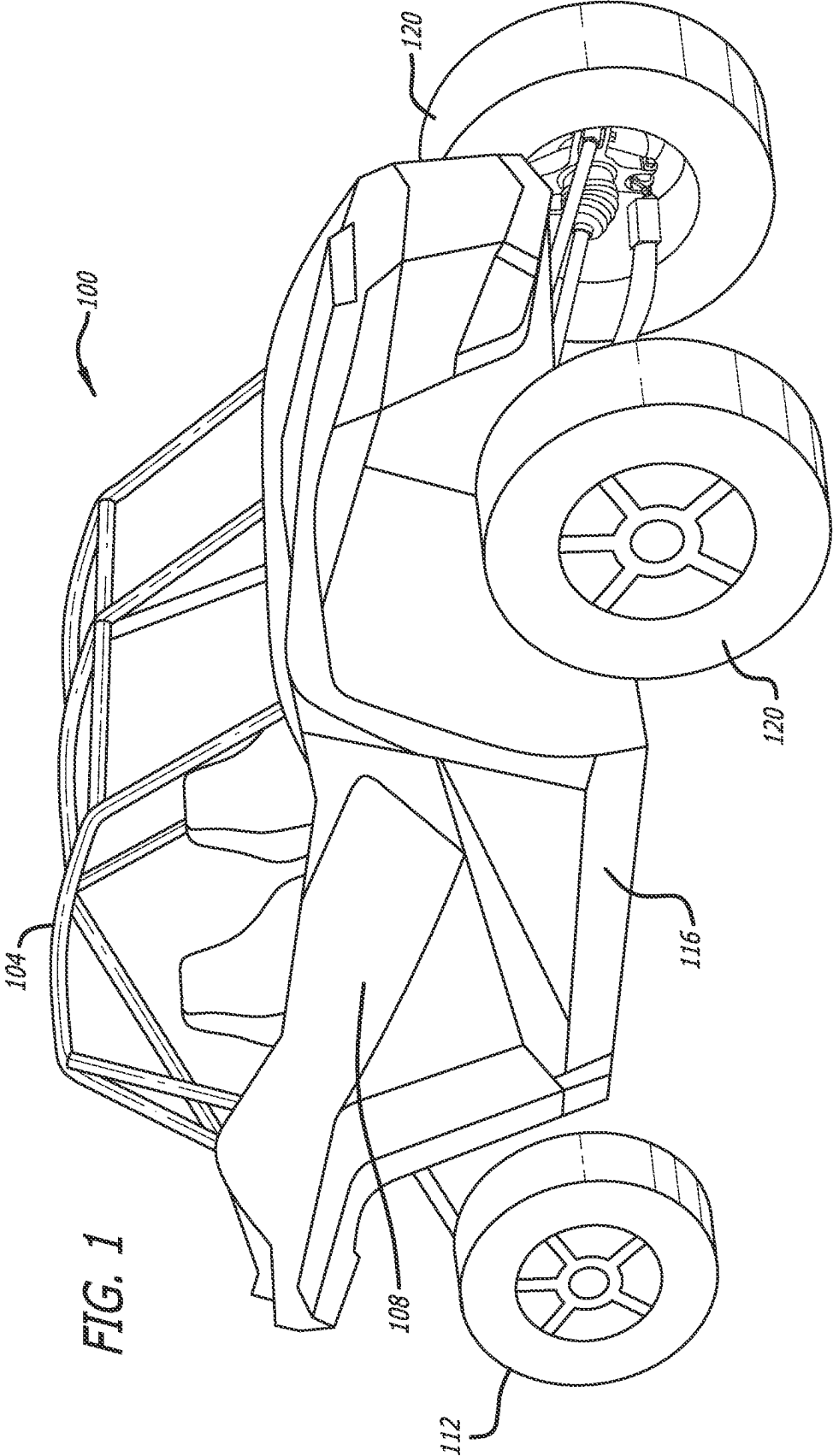

FIG. 1

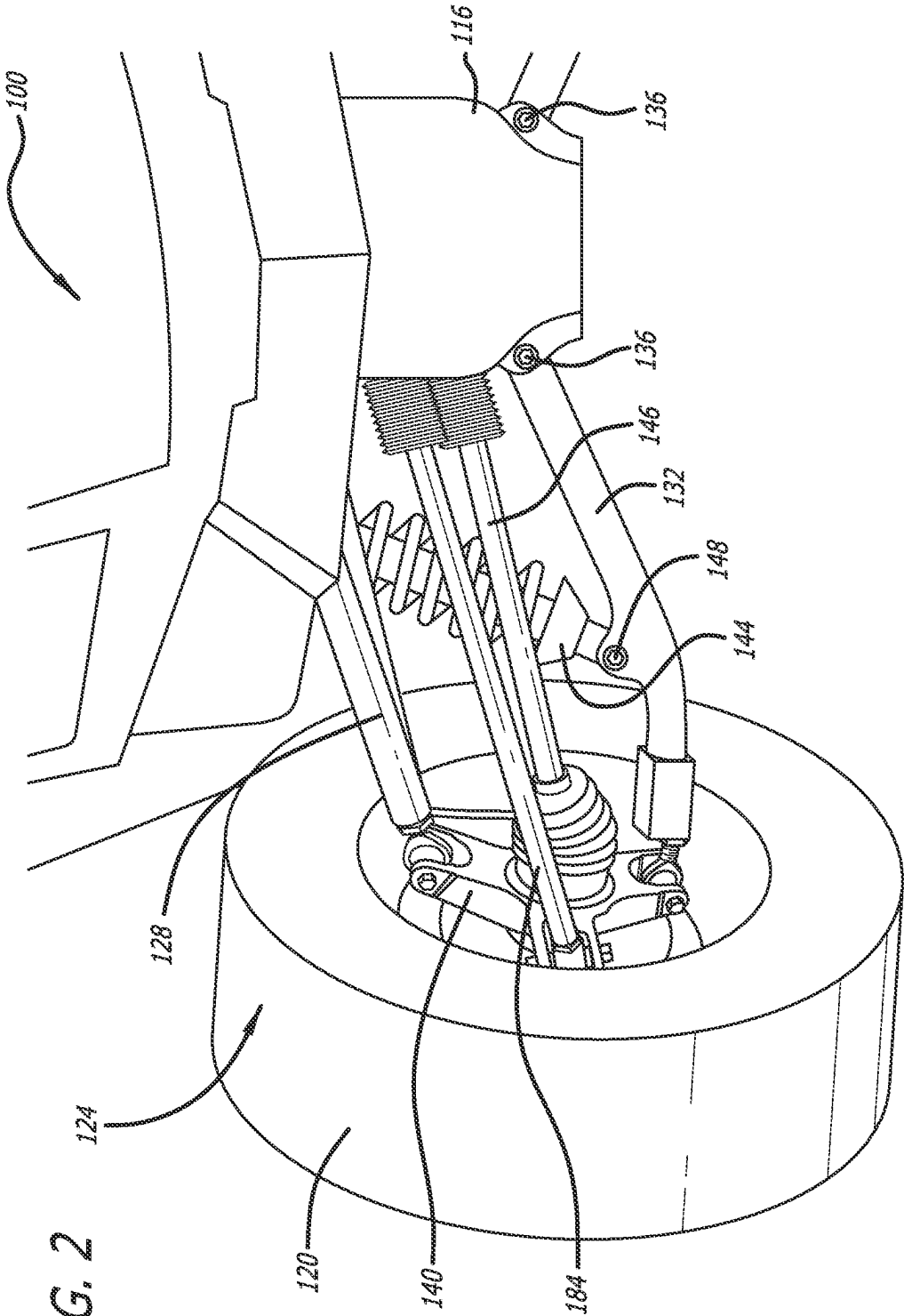

FIG. 2

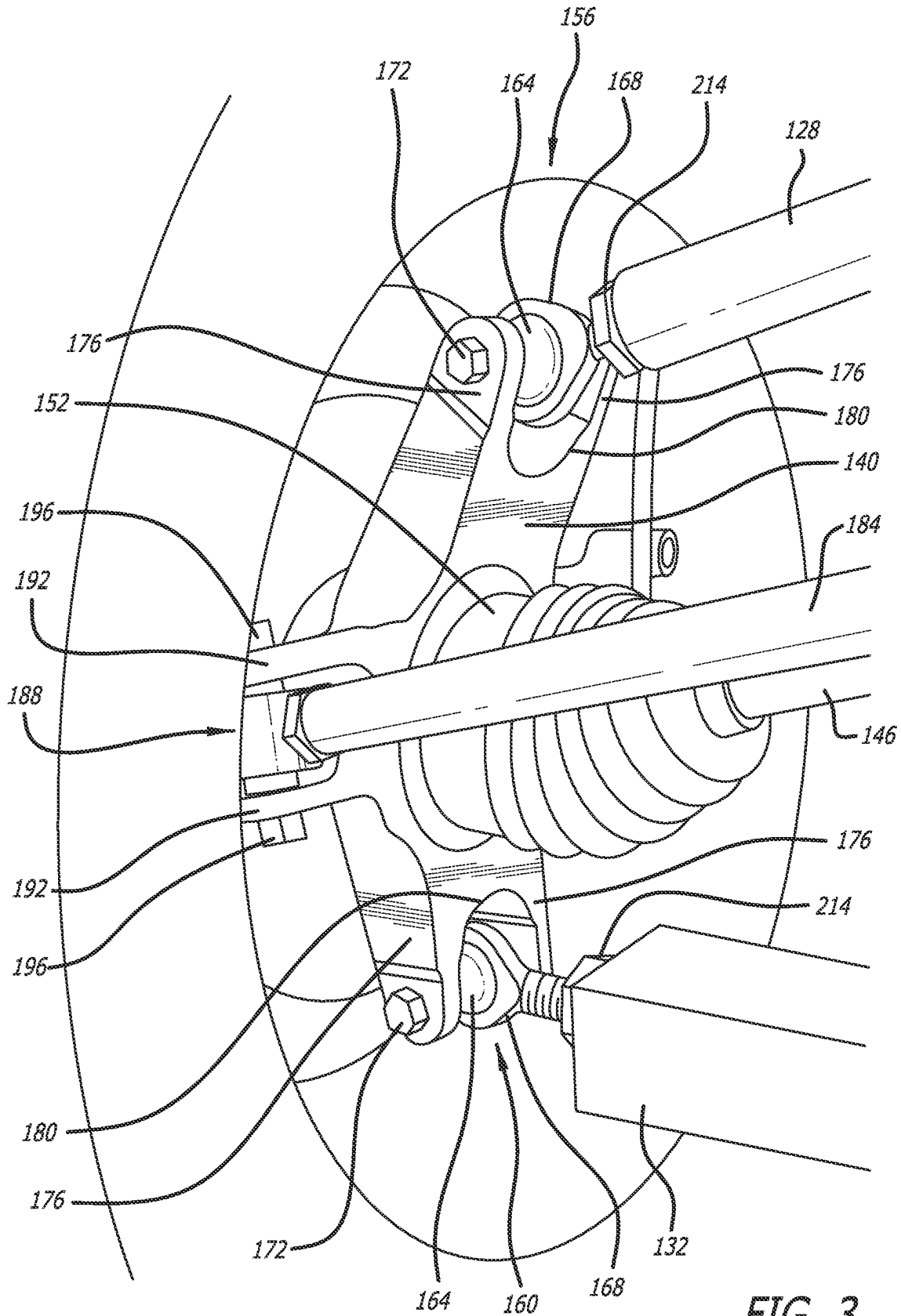

FIG. 3

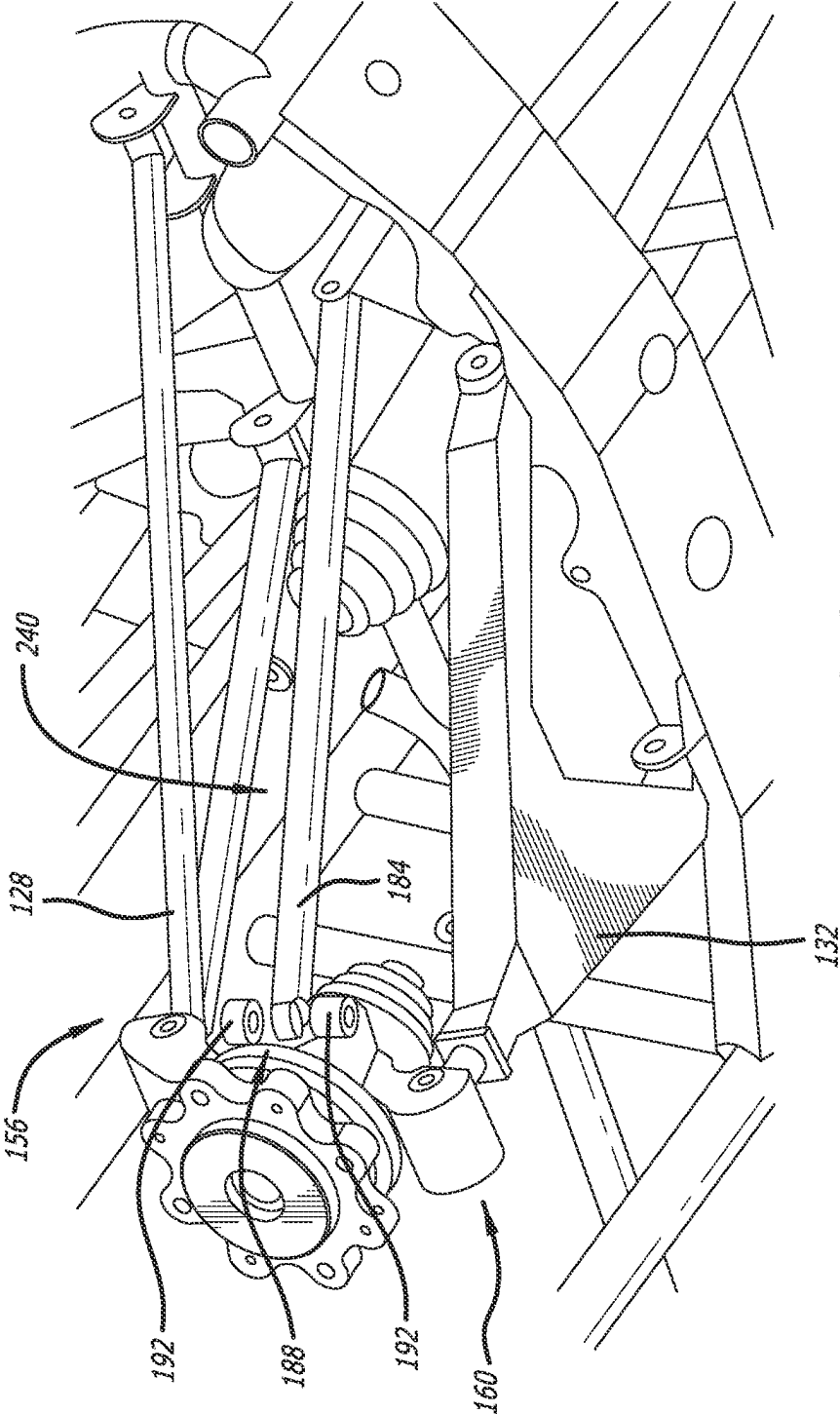

FIG. 3A

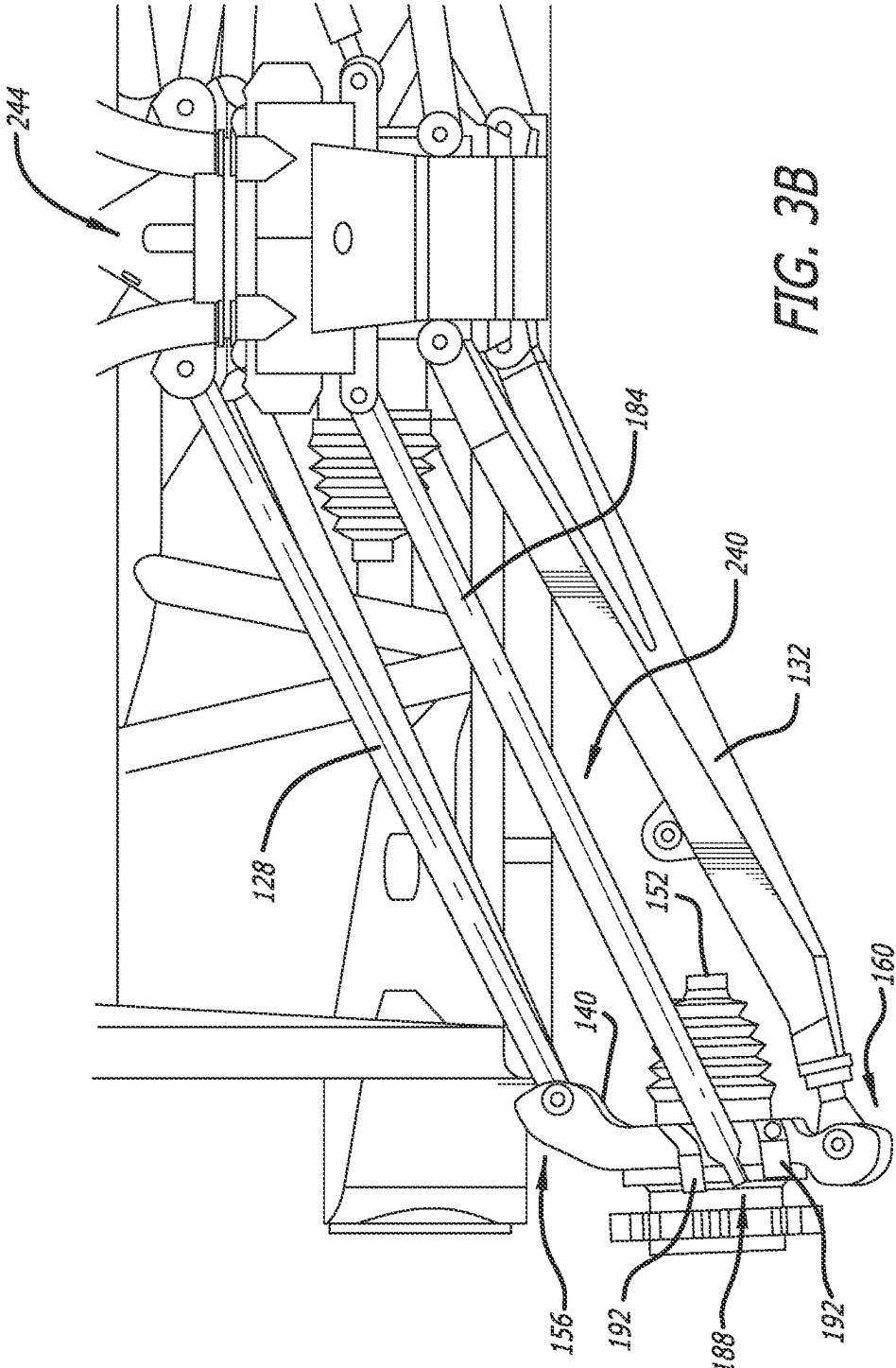

FIG. 3B

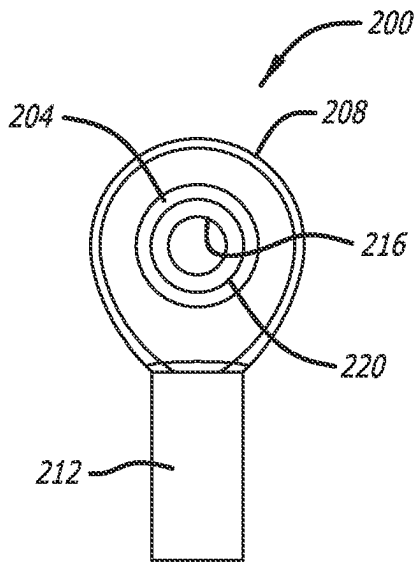

FIG. 4A

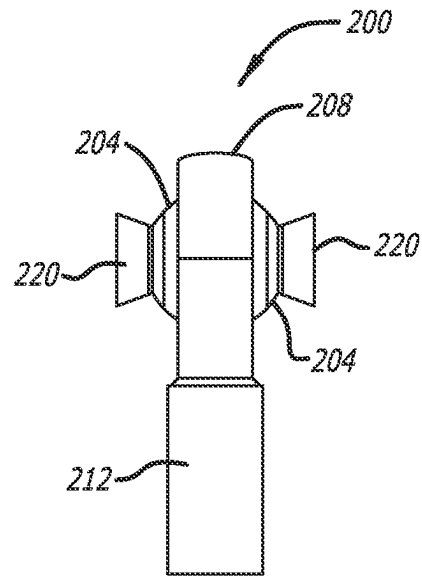

FIG. 4B

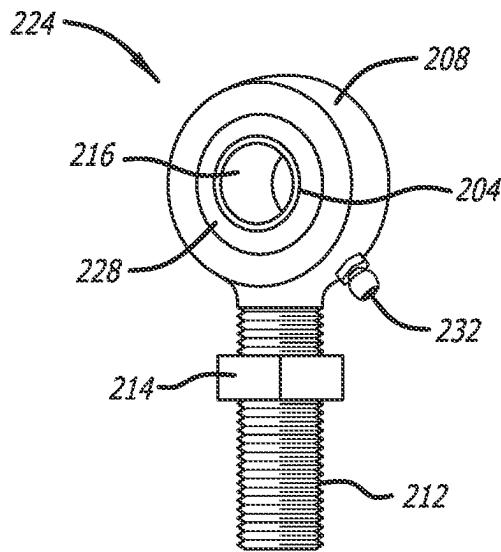

FIG. 5

LEADING-EDGE STEERING ASSEMBLY

PRIORITY

This application is a continuation of U.S. patent application Ser. No. 17/188,636 filed on Mar. 1, 2021 and U.S. patent application Ser. No. 16/422,180 filed on May 24, 2019, issued as U.S. Pat. No. 10,940,886 and U.S. patent application Ser. No. 15/625,813, filed on Jun. 16, 2017, issued as U.S. Pat. No. 10,414,434 issued on Sep. 17, 2019, which claims the benefit of and priority to U.S. Provisional Application No. 62/480,960, filed Apr. 3, 2017, the entirety of which applications are being incorporated herein by reference.

FIELD

The field of the present disclosure generally relates to vehicle suspension systems. More particularly, the field of the invention relates to an off-road front suspension system configured to improve the mechanical strength and performance of off-road drivetrains.

BACKGROUND

A double wishbone suspension is a well-known independent suspension design using upper and lower wishbone-shaped arms to operably couple a front wheel of a vehicle. Typically, the upper and lower wishbones or suspension arms each has two mounting points to a chassis of the vehicle and one mounting joint at a spindle assembly or knuckle. A shock absorber and a coil spring may be mounted onto the wishbone to control vertical movement of the front wheel. The double wishbone suspension facilitates control of wheel motion throughout suspension travel, including controlling such parameters as camber angle, caster angle, toe pattern, roll center height, scrub radius, scrub, and the like.

Double wishbone suspensions may be used in a wide variety of vehicles, including heavy-duty vehicles, as well as many off-road vehicles, as shown in FIG. 1. FIG. 1 shows an off-road vehicle 100 that is of a Side by Side variety. The Side by Side is a four-wheel drive off-road vehicle that typically seats between two and six occupants, and is sometimes referred to as a Utility Task Vehicle (UTV), a Recreational Off-Highway Vehicle (ROV), or a Multipurpose Off-Highway Utility Vehicle (MOHUV). In addition to the side-by-side seating arrangement, many UTVs have seat belts and roll-over protection, and some may have a cargo box at the rear of the vehicle. A majority of UTVs come factory equipped with hard tops, windshields, and cab enclosures.

The double-wishbone suspension often is referred to as "double A-arms", although the arms may be A-shaped, L-shaped, J-shaped, or even a single bar linkage. In some embodiments, the upper arm may be shorter than the lower arm so as to induce negative camber as the suspension jounces (rises). Preferably, during turning of the vehicle, body roll imparts positive camber gain to the lightly loaded inside wheel, while the heavily loaded outer wheel gains negative camber.

The spindle assembly, or knuckle, is coupled between the outboard ends of the upper and lower suspension arms. In some designs, the knuckle contains a kingpin that facilitates horizontal radial movement of the wheel, and rubber or trunnion bushings for vertical hinged movement of the wheel. In some relatively newer designs, a ball joint may be

disposed at each outboard end to allow for vertical and radial movement of the wheel. A bearing hub, or a spindle to which wheel bearings may be mounted, may be coupled with the center of the knuckle.

Constant velocity (CV) joints allow pivoting of the suspension arms and the spindle assembly, while a drive shaft coupled to the CV joint delivers power to the wheels. Although CV joints are typically used in front wheel drive vehicles, off-road vehicles such as four-wheeled buggies comprise CV joints at all wheels. Constant velocity joints typically are protected by a rubber boot and filled with molybdenum disulfide grease.

Given that off-road vehicles routinely travel over very rough terrain, such as mountainous regions, there is a desire to improve the mechanical strength and performance of off-road drivetrain and suspension systems, while at the same reducing the mechanical complexity of such systems.

SUMMARY

A leading-edge steering system is provided for a front suspension of an off-road vehicle. The leading-edge steering system is comprised of a spindle assembly configured to support a drive axle assembly to conduct torque from a transaxle to a front wheel. A first rod-end joint is configured to pivotally couple an upper suspension arm and the spindle assembly, and a second rod-end joint is configured to pivotally couple a lower suspension arm and the spindle assembly. A steering rod-end joint pivotally couples a first end of a steering rod with a leading-edge portion of the spindle assembly. The steering rod-end joint may be either a Heim joint or a bushing joint. A steering gear is disposed in a chassis of the off-road vehicle and coupled with a second end of the steering rod. The steering gear is configured to move the steering rod with respect to the spindle assembly, such that moving the steering rod rotates the spindle assembly with respect to the upper suspension arm and the lower suspension arm. The leading-edge portion is configured to exert primarily tensile forces on the steering rod during traveling of the front wheel over rough terrain.

In an exemplary embodiment, a leading-edge steering system for a front suspension of an off-road vehicle comprises a spindle assembly configured to support a drive axle assembly to conduct torque from a transaxle to a front wheel; a first rod-end joint configured to pivotally couple an upper suspension arm and the spindle assembly; a second rod-end joint configured to pivotally couple a lower suspension arm and the spindle assembly; a steering rod-end joint configured to pivotally couple a first end of a steering rod with a leading-edge portion of the spindle assembly; and a steering gear disposed in a chassis of the off-road vehicle and coupled with a second end of the steering rod.

In another exemplary embodiment, the leading-edge portion of the spindle assembly is comprised of two parallel prongs extending forward with respect to the drive axle, the parallel prongs being configured to fixedly receive a bolt that hingedly receives the steering rod-end joint, such that moving the steering rod rotates the spindle assembly with respect to the upper suspension arm and the lower suspension arm.

In another exemplary embodiment, the steering rod-end joint is comprised of a bushing that couples the steering rod with the spindle assembly, such that moving the steering rod rotates the spindle assembly with respect to the upper suspension arm and the lower suspension arm. In another exemplary embodiment, the bushing is configured to hingedly couple the steering rod with a bolt that is fastened through two parallel prongs extending forwardly from the

3

spindle assembly. In another exemplary embodiment, the bushing is configured to facilitate horizontal rotation of the spindle assembly with respect to the upper suspension arm and the lower suspension arm during vertical motion of the spindle assembly during operation of the off-road vehicle.

In another exemplary embodiment, the steering rod-end joint is comprised of a ball that is rotatable within a casing that is threadably coupled with the steering rod, such that moving the steering rod rotates the spindle assembly with respect to the upper suspension arm and the lower suspension arm. In another exemplary embodiment, the ball is configured to be fastened by way of a bolt between a pair of parallel prong extending forwardly from the spindle assembly, such that moving the steering rod rotates the spindle assembly horizontally with respect to the upper suspension arm and the lower suspension arm during vertical motion of the spindle assembly due to operation of the off-road vehicle. In another exemplary embodiment, the steering rod-end joint is coupled with the spindle assembly forward of the drive axle so as to advantageously decrease leverage of the front wheel on the steering rod and substantially eliminate bump steer that may occur due to traveling over rough terrain.

In another exemplary embodiment, the steering gear is configured to move the steering rod rightward during clockwise turning of the steering gear, and wherein the steering gear is configured to move the steering rod leftward during counterclockwise turning of the steering gear. In another exemplary embodiment, the leading-edge portion is configured to rotate the spindle assembly rightward during clockwise turning of the steering gear, and wherein the leading-edge portion is configured to rotate the spindle assembly leftward during counterclockwise turning of the steering gear. In another exemplary embodiment, the leading-edge portion is configured to exert primarily tensile forces on the steering rod during traveling of the front wheel over rough terrain. In another exemplary embodiment, the leading-edge portion is configured to substantially eliminate bump steer that may occur due to forces exerted on the front wheel by the rough terrain.

BRIEF DESCRIPTION OF THE DRAWINGS

The drawings refer to embodiments of the present disclosure in which:

FIG. 1 illustrates an exemplary embodiment of an off-road vehicle that is particularly suitable for implementation of an off-road front suspension system in accordance with the present disclosure;

FIG. 2 illustrates a front view of a front suspension system that is configured to couple a front wheel with a passenger side of an off-road vehicle;

FIG. 3 illustrates a front view of an exemplary embodiment of outboard rod-end joints coupling a spindle assembly with upper and lower suspension arms;

FIG. 3A illustrates a lower isometric view of an exemplary embodiment of a leading-edge steering system that may be incorporated into the front suspension of the off-road vehicle;

FIG. 3B illustrates a front plan view of the leading-edge steering system of FIG. 3A;

FIG. 4A illustrates a front plan view of an exemplary embodiment of rod-end joint coupling a spindle assembly with a suspension arm;

FIG. 4B illustrates a side plan view of the rod-end joint of FIG. 4A; and

4

FIG. 5 illustrates a perspective view of an exemplary embodiment of rod-end joint that includes a lubricating race and a lubrication fitting.

While the present disclosure is subject to various modifications and alternative forms, specific embodiments thereof have been shown by way of example in the drawings and will herein be described in detail. The invention should be understood to not be limited to the particular forms disclosed, but on the contrary, the intention is to cover all modifications, equivalents, and alternatives falling within the spirit and scope of the present disclosure.

DETAILED DESCRIPTION

In the following description, numerous specific details are set forth in order to provide a thorough understanding of the present disclosure. It will be apparent, however, to one of ordinary skill in the art that the invention disclosed herein may be practiced without these specific details. In other instances, specific numeric references such as “first joint,” may be made. However, the specific numeric reference should not be interpreted as a literal sequential order but rather interpreted that the “first joint” is different than a “second joint.” Thus, the specific details set forth are merely exemplary. The specific details may be varied from and still be contemplated to be within the spirit and scope of the present disclosure. The term “coupled” is defined as meaning connected either directly to the component or indirectly to the component through another component. Further, as used herein, the terms “about,” “approximately,” or “substantially” for any numerical values or ranges indicate a suitable dimensional tolerance that allows the part or collection of components to function for its intended purpose as described herein.

In general, the present disclosure describes a suspension for coupling a front wheel with a chassis of an off-road vehicle. The suspension comprises an upper suspension arm that includes two inboard mounting points to the chassis and one outboard rod-end joint to a spindle assembly coupled with the front wheel. A lower suspension arm comprises two inboard mounting points to the chassis and one outboard rod-end joint to the spindle assembly. Each outboard rod-end joint is comprised of a ball that is rotatable within a casing that is threadably coupled with each of the upper and lower suspension arms. A bolt fastens each of the balls between a pair of parallel prongs extending from the spindle assembly, such that the upper and lower suspension arms may pivot with respect to the spindle assembly during vertical motion of the spindle assembly, as well as during horizontal rotation of the spindle assembly due to steering. A strut comprising a shock absorber and a coil spring is coupled between the lower suspension arm and the chassis. The upper suspension arm is configured to facilitate coupling the strut between the lower suspension arm and the chassis. A steering rod is coupled with the spindle assembly by way of a steering rod-end joint that is disposed at a front of the spindle assembly. The steering rod-end joint is comprised of a ball that is rotatable within a casing that is threadably coupled with the steering rod. A pair of parallel prongs and a bolt hingedly couple the steering rod-end with the spindle assembly, such that the steering rod-end joint allows vertical and horizontal rotational motion of the spindle assembly during operation of the off-road vehicle. The steering rod-end joint is coupled with the spindle assembly forward of a drive axle, thereby decreasing leverage of the front wheel on the steering rod and substantially eliminating bump steer that may occur due to rough terrain.

5

FIG. 1 shows an off-road vehicle **100** that is particularly suitable for implementation of an off-road front suspension system in accordance with the present disclosure. As disclosed hereinabove, the off-road vehicle **100** generally is of a Utility Task Vehicle (UTV) variety that seats two occupants, includes a roll-over protection system **104**, and may have a cab enclosure **108**. Rear wheels **112** of the off-road vehicle **100** may be operably coupled with a chassis **116** by way of a trailing arm suspension system. Front wheels **120** may be operably coupled with the chassis **116** by way of the front suspension system disclosed herein. It should be understood, however, that the front suspension system of the present disclosure is not to be limited to the off-road vehicle **100**, but rather the front suspension system may be incorporated into a wide variety of off-road vehicles, other than UTVs, without limitation.

FIG. 2 illustrates a front view of a front suspension system **124** that is configured to couple the front wheel **120** with a passenger side of the off-road vehicle **100**. The front suspension system **124** is comprised of an upper suspension arm **128** and a lower suspension arm **132** that couple the front wheel **120** with the chassis **116**. Each of the upper and lower suspension arms **128**, **132** comprises two inboard mounting points **136** to the chassis **116** and one outboard mounting joint to a spindle assembly **140**. As will be recognized, the upper and lower suspension arms **128**, **132** generally are of a double wishbone variety of suspension that facilitates controlling various parameters affecting the orientation of the wheel **120** with respect to the off-road vehicle **100**, such as, by way of non-limiting example, camber angle, caster angle, toe pattern, roll center height, scrub radius, and scuff.

It should be understood that although the front suspension system **124** is disclosed specifically in connection with the passenger side of the off-road vehicle **100**, a driver side front suspension system is to be coupled with a driver side of the off-road vehicle. It should be further understood that the driver side front suspension system is substantially identical to the front suspension system **124**, with the exception that the driver side front suspension system is configured specifically to operate with the driver side of the off-road vehicle **100**. As will be appreciated, therefore, the driver side front suspension system and the front suspension system **124** may be configured as reflections of one another across a longitudinal midline of the off-road vehicle **100**.

As shown in FIG. 2, a strut **144** that is comprised of a shock absorber and a coil spring is mounted to the lower suspension arm **132** by way of a lower pivot **148**. An upper pivot (not shown) couples a top of the strut **144** to the chassis **116**. The strut **144** is configured to control vertical motion of the front suspension system **124** due to movement of the front wheel **120** as the off-road vehicle **100** travels over bumpy terrain. The upper suspension arm **128** may be suitably configured, such as in the form of a J-arm, so as to facilitate coupling the strut **144** between the lower suspension arm **132** and the chassis **116** in lieu of being coupled between the upper suspension arm and the chassis.

In some embodiments, coupling the strut **144** with the lower suspension arm **132** positions the strut at between 8 inches and 10 inches lower, with respect to the chassis **116**, than the position of the strut when coupled with the upper suspension arm **128**. Experimental observation has shown that the lower position of the strut **144** generally facilitates a lower center of gravity of the off-road vehicle **100** and a relatively smaller shock angle, as well as eliminating a need for extending the strut towers through and above a hood of the off-road vehicle **100**. In one embodiment, the coupling of

6

the strut **144** with the lower suspension arm **132** positions the strut at substantially 90-degrees with respect to the lower pivot **148** and the upper pivot during full compression of the strut.

As shown in FIG. 2, a drive axle **146** is coupled between a transaxle and the front wheel **120**. The drive axle **146** is configured to conduct torque from the transaxle to the front wheel **120** and accommodate vertical pivoting motion of the front suspension assembly **124** in response to road conditions. As best shown in FIG. 3, the drive axle **146** is comprised of a constant velocity (CV) joint **152** that is coupled with the spindle assembly **140** onto which the front wheel is mounted. The CV joint **152** allows uninterrupted torque transmission from the transaxle to the front wheel **120** during vertical pivoting of the front suspension assembly **124** due to road conditions. As will be appreciated, the spindle assembly **140** generally supports the CV joint **152** and the front wheel **120** by way of one or more roller bearings (not shown).

As further shown in FIG. 3, the spindle assembly **140** is pivotally coupled with the upper and lower suspension arms **128**, **132**. An upper rod-end joint **156** couples the upper suspension arm **128** to the spindle assembly **140**, and a lower rod-end joint **160** couples the lower suspension arm **132** to the spindle assembly. Preferably, the upper and lower rod-end joints **156**, **160** are of a Heim-joint variety, wherein each of the joints is comprised of a ball **164** that is movable within a casing **168** that is threadably coupled with each of the suspension arms **128**, **132**. A bolt **172** fastens each of the balls **164** between a pair of parallel prongs **176** extending from the spindle assembly **140**. It is contemplated that a recess **180** disposed between each pair of parallel prongs **176** has a shape and a size that are suitable to fixedly receive the ball **164** and allow for a desired degree of movement of the casing **168** on the ball. Thus, during vertical motion of the spindle assembly **140**, as well as during horizontal rotation of the spindle assembly **140** due to steering, the balls **164** rotate within their respective casings **168**, allowing the upper and lower suspension arms **128**, **132** to pivot with respect to the spindle assembly **140**.

Upon inspection of FIG. 3, it will be recognized that the upper and lower rod-end joints **156**, **160** are similar to Clevis fasteners. For example, each pair of parallel prongs **176** is similar to a Clevis, the bolt **172** is similar to a Clevis pin, and the ball **164** and casing **168** are similar to a tang. As such, each of the upper and lower rod-end points **156**, **160** provides two shear planes that may withstand twice the incident force that may be withstood by single shear joints that are used in conventional front suspensions.

In the embodiment illustrated in FIG. 3, a steering rod **184** couples the spindle assembly **140** with a steering system of the off-road vehicle **100**. The steering rod **184** is coupled with the spindle assembly **140** by way of a rod-end joint **188** that is similar to the upper and lower rod-end joints **156**, **160**. It is contemplated, therefore, that the rod-end joint **188** may be of the Heim-joint variety or may be of a bushing variety, as desired. A pair of parallel prongs **192** and a bolt **196** hingedly couple the steering rod **184** with the spindle assembly **140**. As will be appreciated, the rod-end joint **188** allows vertical and horizontal rotational motion of the spindle assembly **140** during operation of the off-road vehicle **100**.

In the embodiment illustrated in FIG. 3, the rod-end joint **188** is coupled with the spindle assembly **140** forward of the drive axle **146**, thereby providing a leading-edge steering system to the off-road vehicle **100**. Experimentation has demonstrated that the leading-edge steering system shown in

FIG. 3 advantageously decreases leverage of the front wheel **120** on the rod-end joint **188** and the steering rod **184**, thereby substantially eliminating bump steer that may occur due to forces exerted on the front wheel by rough terrain. In another exemplary embodiment, the steering rod-end joint is comprised of a bushing **189** that couples the steering rod with the spindle assembly, such that moving the steering rod rotates the spindle assembly with respect to the upper suspension arm and the lower suspension arm. In another exemplary embodiment, the bushing **189** is configured to hingedly couple the steering rod with a bolt that is fastened through two parallel prongs extending forwardly from the spindle assembly. In another exemplary embodiment, the bushing **189** is configured to facilitate horizontal rotation of the spindle assembly with respect to the upper suspension arm and the lower suspension arm during veicular motion of the spindle assembly during operation of the off-road vehicle.

FIGS. 3A-3B illustrate an exemplary embodiment of a leading-edge steering system **240** that is advantageously incorporated into the front suspension of the off-road vehicle **100**. Similar to the embodiment illustrated in FIG. 3, the leading-edge steering system **240** is comprised of a steering rod **184** that is coupled with the spindle assembly **140** by way of a rod-end joint **188** that is disposed forward of the drive axle **146**. As disclosed above, the rod-end joint **188** may be of the Heim-joint variety or may be of a bushing variety, such that the rod-end joint **188** allows vertical and horizontal rotational motion of the spindle assembly **140**. Opposite of the rod-end joint **188**, the steering rod **184** is coupled with a steering gear **244** that is mounted onto a central location of the chassis **116**. During operating the off-road vehicle, turning the steering gear **244** clockwise moves the steering rod **184** toward the spindle assembly **140**, causing the front wheel **120** to turn rightward. Turning the steering gear **244** moves the steering rod **184** away from the spindle assembly **140**, thereby turning the front wheel **120** leftward.

During traveling over rough terrain, the steering rods **184** comprising the leading-edge steering system **240** are exposed primarily to tensile forces, unlike tie-rods comprising conventional trailing-edge steering systems that endure primarily compression forces. It will be recognized by those skilled in the art that although the yield strength of steel generally is independent of tension and compression, the steering rod **184** generally may support a greater load in tension than in compression. As will be appreciated, a tensile force requires all sections of the steering rod **184** to yield before failure of the steering rod may occur, whereas in the case of a compression force, failure of the steering rod **184** due to buckling generally requires a relatively lower force acting at a weakest section of the rod. Under the action of the compression force, therefore, failure of the steering rod **184** may occur when any one section of the steel fails rather than requiring all sections to fail as occurs with tensile forces. As such, the leading-edge steering system **240** is capable of withstanding relatively much greater forces due to rough terrain than may be tolerated by conventional, trailing-edge steering systems.

FIGS. 4A-4B illustrate an exemplary embodiment of a rod-end **200** that may be pivotally coupled with either of the upper and lower suspension arms **128**, **132** of the spindle assembly **140**, as described herein. Like the rod-end joints **156**, **160**, the rod-end **200** is generally of the Heim-joint variety. The rod-end **200** is comprised of a ball **204** that is retained within a casing **208**, such that the ball **204** may be rotated within the casing **208**. A threaded shank **212**, or a

weld-in tube end, is fixedly coupled with the casing **208** so as to enable coupling the rod-end to one of the suspension arms **128**, **132**. The threaded shank **212** may be fixedly coupled with the suspension arm by way of a lock-nut **214** (see FIG. 5) that may be threaded onto the shank **212** and rotated into forcible contact with the suspension arm. It is contemplated that the threaded shank **212** may be configured with left-hand threads or right-hand threads, without limitation.

A bore **216** extends through the ball **204** and is configured to receive the bolt **172**. The bore **216** and the bolt **172** facilitate mounting the rod-end **200** to the spindle assembly **140**. In particular, the bolt **172** may be passed through suitable threaded holes in the prongs **176** and through the bore **216** so as to fixate the ball **204** in the recess **180**. With the ball **204** fixated between the parallel prongs **176**, the casing **208** and the suspension arm to which the rod-end **200** is fastened may be freely moved with respect to the spindle assembly **140**.

As best shown in FIG. 4B, a misalignment spacer **220** may be disposed on each of opposite sides of the ball **204**. The misalignment spacers **220** ensure that the ball **204** remains centered within the recess **180**, between the parallel prongs **176**, while providing a relatively high degree of clearance for rotation of the casing **208** on the ball **204**. In some embodiments, the misalignment spacers **220** may be threaded or press-fitted into suitable countersunk holes in the ball **204**. In some embodiments, the ball **204** and the misalignment spacers **220** may be machined as a single component comprising an extended ball that may be installed into the casing **208** during manufacturing of the rod-end **200**.

In some embodiments, a lubricating race may be incorporated into the rod-end as to ensure sufficient lubrication is available to the ball and casing during operation of the rod-end. For example, in an exemplary embodiment of a rod-end **224**, illustrated in FIG. 5, a lubricating race **228** is disposed between the ball **204** and an interior of the casing **208**. In some embodiments, the lubricating race **228** may be comprised of a heavy duty, injection molded Teflon impregnated Nylon race that is configured to ensure smooth and precise movement of the ball **204** within the casing **208**. In some embodiments, the lubricating race **228** may be comprised of a thin chamber between the ball **204** and an interior of the casing **208**. A suitable lubricant, such as a high-quality grease, may be disposed within the thin chamber so as to lubricate movement between the ball **204** and the casing **208**. A lubrication fitting **232** may be disposed in the casing **208** and in fluid communication with the thin chamber to facilitate periodic replenishment of the lubricant within the thin chamber.

In some embodiments, the rod-ends **200**, **224** may be configured to have self-lubricating properties. For example, in some embodiments, the balls and casings **204**, **208** may be comprised of stainless steel that is treated with polytetrafluoroethylene (PTFE). It is contemplated that any of various PTFE-based formulations may be applied to the rod-ends **200**, **224**, without limitation. In some embodiments, PTFE-treated stainless steel balls and casings **204**, **208** may be coupled with a lubricating race **228** that is comprised of an injection molded Teflon impregnated Nylon race, without limitation.

It is contemplated that the rod-ends **200**, **224** may be treated during manufacturing so as to optimize hardness, strength, durability, and longevity. In some embodiments, the casings **208** may be machined **4130** chromoly, or any other suitable material, and the balls **204** may be comprised

of 52100 bearing steel, or any other suitable material. The balls and casings **204, 208** may be heat-treated and hard-chrome finished so as to improve strength and corrosion resistance. Further, the balls and casings **204, 208**, as well as the race **228**, may be cryogenically treated to improve hardness, durability, and wear resistance.

While the invention has been described in terms of particular variations and illustrative figures, those of ordinary skill in the art will recognize that the invention is not limited to the variations or figures described. In addition, where methods and steps described above indicate certain events occurring in certain order, those of ordinary skill in the art will recognize that the ordering of certain steps may be modified and that such modifications are in accordance with the variations of the invention. Additionally, certain of the steps may be performed concurrently in a parallel process when possible, as well as performed sequentially as described above. To the extent there are variations of the invention, which are within the spirit of the disclosure or equivalent to the inventions found in the claims, it is the intent that this patent will cover those variations as well. Therefore, the present disclosure is to be understood as not limited by the specific embodiments described herein, but only by scope of the appended claims.

What is claimed is:

1. A leading-edge steering assembly for a vehicle, the assembly comprising:

a first steering rod coupled between a steering gear and a first spindle assembly;

a second steering rod coupled between the steering gear and a second spindle assembly; and

a first rod end joints connecting the first spindle assembly with a first upper suspension arm and a first lower suspension arm and a second rod end joints connecting the second spindle assembly with a second upper suspension arm and a second lower suspension arm, wherein each of the first rod end joints and the second rod end joints are configured to provide two shear planes;

wherein each of the first spindle assembly and the second spindle assembly includes a leading-edge portion, the leading-edge portions are configured to be coupled to the first steering rod and the second steering rod respectively through third rod end joints, wherein each of the leading-edge portions extends forward of a respective drive axle,

wherein each of the first spindle assembly and the second spindle assembly are of substantially T-shape, wherein the spindle has three parallel prong shape extensions at three corners of the T-shape spindle for the two suspension arms and the steering rod, wherein a recess in each of the parallel prong shape extension is configured to receive a ball of a rod end joint,

wherein each of the first rod end joint, the second rod end joint, and the third rod end joint comprises:

a ball rotatably retained within a casing, the ball has a bore passing through a center of the ball and configured to receive a fastener, wherein each of the parallel prong shape extensions has threaded holes for the fastener to pass through securing the ball;

a threaded shank extending from the casing; and

a misalignment spacer disposed on opposite ends of the bore and configured to provide clearance for rotation of the casing on the ball.

2. The assembly of claim **1**, wherein the misalignment spacers are threaded.

3. The assembly of claim **1**, wherein the ball and the misalignment spacers are machined as a single component comprising an extended ball.

4. The assembly of claim **1**, wherein the ball comprises **52100** bearing steel; and wherein the casing comprises machined **4130** chromoly.

5. The assembly of claim **1**, wherein the ball and the casing are heat-treated and hard-chrome finished to improve strength and corrosion resistance.

6. The assembly of claim **1**, wherein the ball and the casing are cryogenically treated to improve hardness, durability, and wear resistance.

7. The assembly of claim **1**, wherein the ball and the casing are configured to exhibit self-lubricating properties.

8. The assembly of claim **1**, wherein the rod-end joint comprises a lubricating race configured to lubricate the ball and casing, wherein the lubricating race is disposed between the ball and an interior of the casing, wherein the lubricating race comprises:

a thin chamber between the ball and the interior of the casing; and

a lubrication fitting disposed in the casing and in fluid communication with the thin chamber, the lubrication fitting configured to receive lubricant.

9. The assembly of claim **8**, wherein the ball and the casing are made of stainless steel treated with polytetrafluoroethylene (PTFE).

10. A method for a leading-edge steering assembly for a vehicle, comprising:

coupling a first steering rod between a steering gear and a first spindle assembly, through rod-end joints;

coupling a second steering rod between a steering gear and a second spindle assembly through rod-end joints; and

connecting each of the first spindle assembly and the second spindle assembly with an upper suspension arm and a lower suspension arm by way of rod-end joints, wherein each of the rod end joints is configured to provide two shear planes;

wherein the first spindle assembly and the second spindle assembly each includes a leading-edge portion configured to be respectively joined with the first steering rod and the second steering rod, wherein each of the leading-edge portion extends perpendicular from a mid-portion of spindles of the first spindle assembly and the second spindle assembly, respectively and forward of a respective drive axle, wherein each of the first spindle assembly and the second spindle assembly are of substantially T-shape, wherein the spindle has three parallel prong shape extensions at three corners of the T-shape spindle for the two suspension arms and the steering rod, wherein a recess in each of the parallel prong shape extension is configured to receive a ball of a rod end joint,

wherein each of the rod end joints comprises:

a ball rotatably retained within a casing, the ball has a bore passing through a center of the ball and configured to receive a fastener, wherein each of the parallel prong shape extensions has threaded holes for the fastener to pass through securing the ball;

a threaded shank extending from the casing; and

a misalignment spacer disposed on opposite ends of the bore and configured to provide clearance for rotation of the casing on the ball,

11

wherein clockwise turning of a steering gear moves the respective steering rod rightward and anti-clockwise turning of a steering gear moves the respective steering rod leftward.

* * * * *

5

12