



US0D1059650S

(12) **United States Design Patent**
Gregor et al.

(10) **Patent No.:** **US D1,059,650 S**

(45) **Date of Patent:** **** Jan. 28, 2025**

(54) **AIRCRAFT CABIN FLOOD LIGHT**

(71) Applicants: **Jakub Gregor**, Palm Coast, FL (US);
Anton Bondariev, Dobris (CZ);
Christian Nielsen, Palm Coast, FL (US)

(72) Inventors: **Jakub Gregor**, Palm Coast, FL (US);
Anton Bondariev, Dobris (CZ);
Christian Nielsen, Palm Coast, FL (US)

(**) Term: **15 Years**

(21) Appl. No.: **29/943,119**

(22) Filed: **May 20, 2024**

(51) **LOC (15) Cl.** **26-06**

(52) **U.S. Cl.**
USPC **D26/35**

(58) **Field of Classification Search**
USPC D26/28-36
CPC F21V 15/01; F21V 17/12; F21V 29/763;
F21V 29/74; F21S 8/04; F21S 2/005;
F21Y 2115/10; F21Y 5/10; B60Q 3/74;
B60Q 3/82; B60Q 3/51; B60Q 3/44;
B60Q 3/53; F21W 2107/30

See application file for complete search history.

(56) **References Cited**

U.S. PATENT DOCUMENTS

D291,253 S *	8/1987	Ortega	D26/29
D299,548 S *	1/1989	Macaluso	D26/29
D300,867 S *	4/1989	Macaluso	D26/74
D326,926 S *	6/1992	Stephenson	D26/74
D591,665 S *	5/2009	Saint-Jalmes	D12/345
D642,721 S *	8/2011	Li	D26/63

D718,478 S *	11/2014	Adams	D26/28
9,035,801 B2 *	5/2015	Nikolic	H05B 47/11 244/50
D988,567 S *	6/2023	Song	D26/63
D1,006,273 S *	11/2023	Finocchiaro	D26/35
D1,035,932 S *	7/2024	Johnson	D26/28

* cited by examiner

Primary Examiner — Natasha Vujcic
Assistant Examiner — Robert B Rieker

(74) *Attorney, Agent, or Firm* — Barry Choobin; Patent 360

(57) **CLAIM**

The ornamental design for an aircraft cabin flood light, as shown and described.

DESCRIPTION

FIG. 1 is a perspective view of a first embodiment of an aircraft cabin flood light, showing our new design; FIG. 2 is a front view thereof; FIG. 3 is a rear view thereof; FIG. 4 is a right side view thereof; FIG. 5 is a left side view thereof; FIG. 6 is a top view thereof; FIG. 7 is a bottom view thereof; FIG. 8 is a perspective view of a second embodiment of the aircraft cabin flood light; FIG. 9 is a front view thereof; FIG. 10 is a rear view thereof; FIG. 11 is a right side view thereof; FIG. 12 is a left side view thereof; FIG. 13 is a top view thereof; and, FIG. 14 is a bottom view thereof.

The broken lines depict portions of the aircraft cabin flood light that form no part of the claimed design.

1 Claim, 13 Drawing Sheets

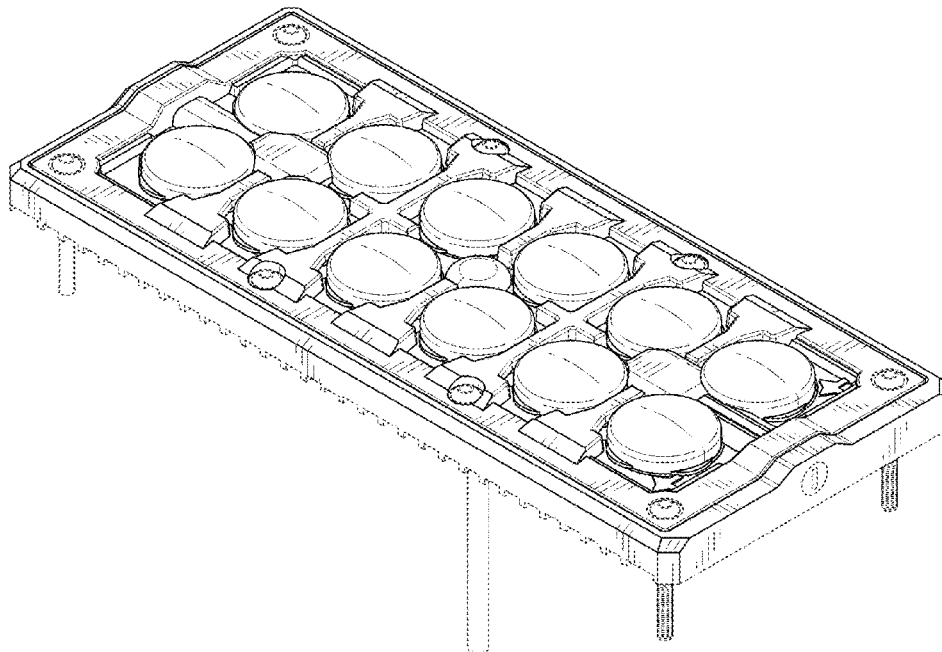

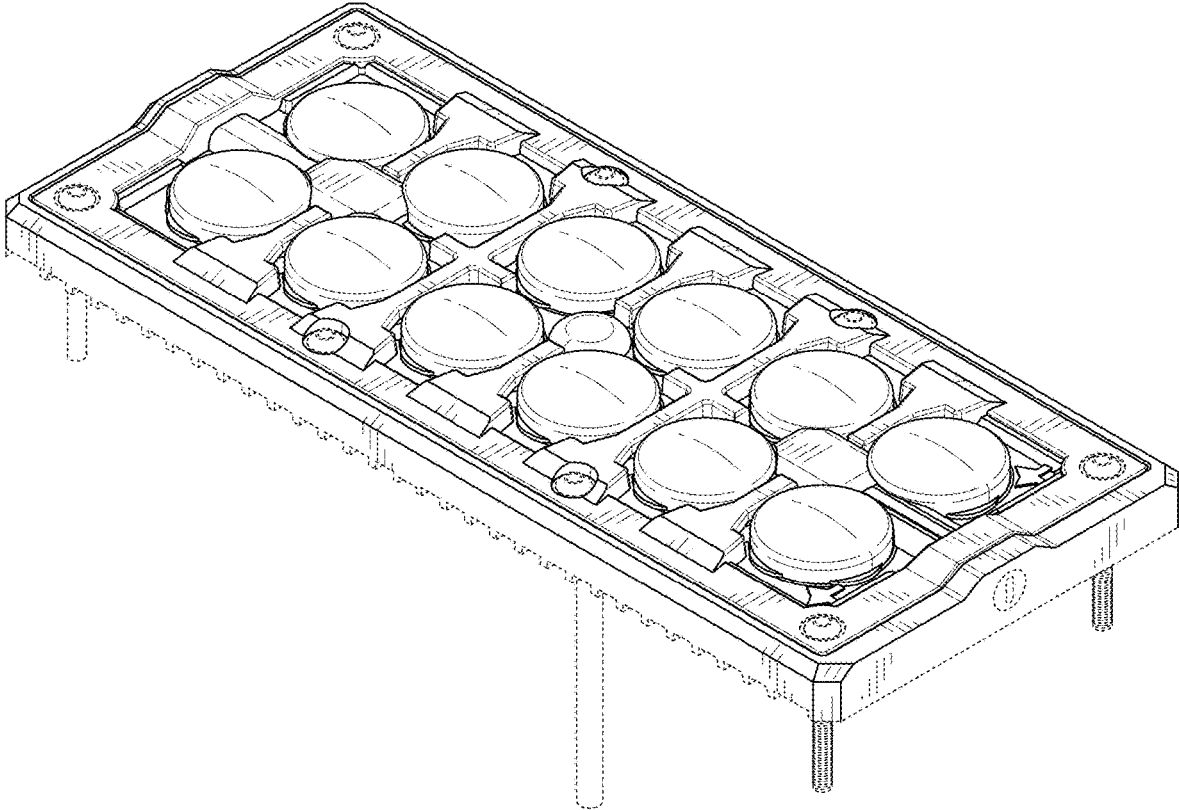

FIG. 1

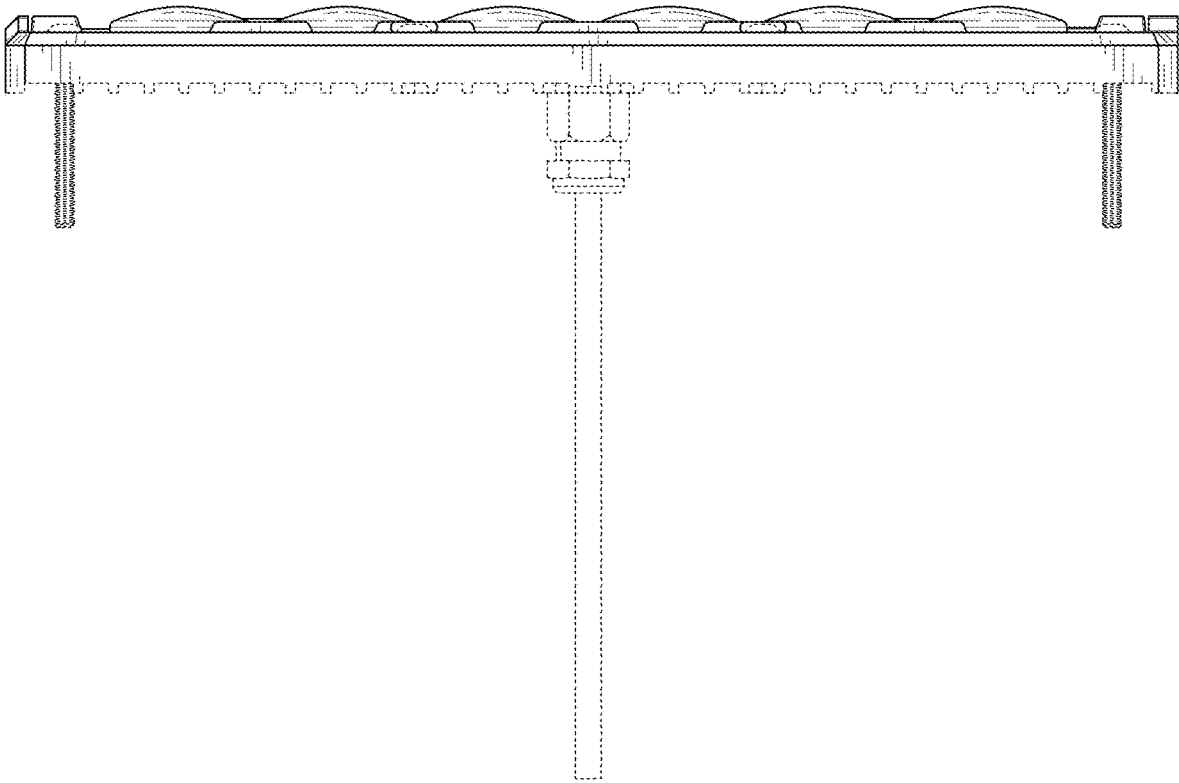

FIG. 2

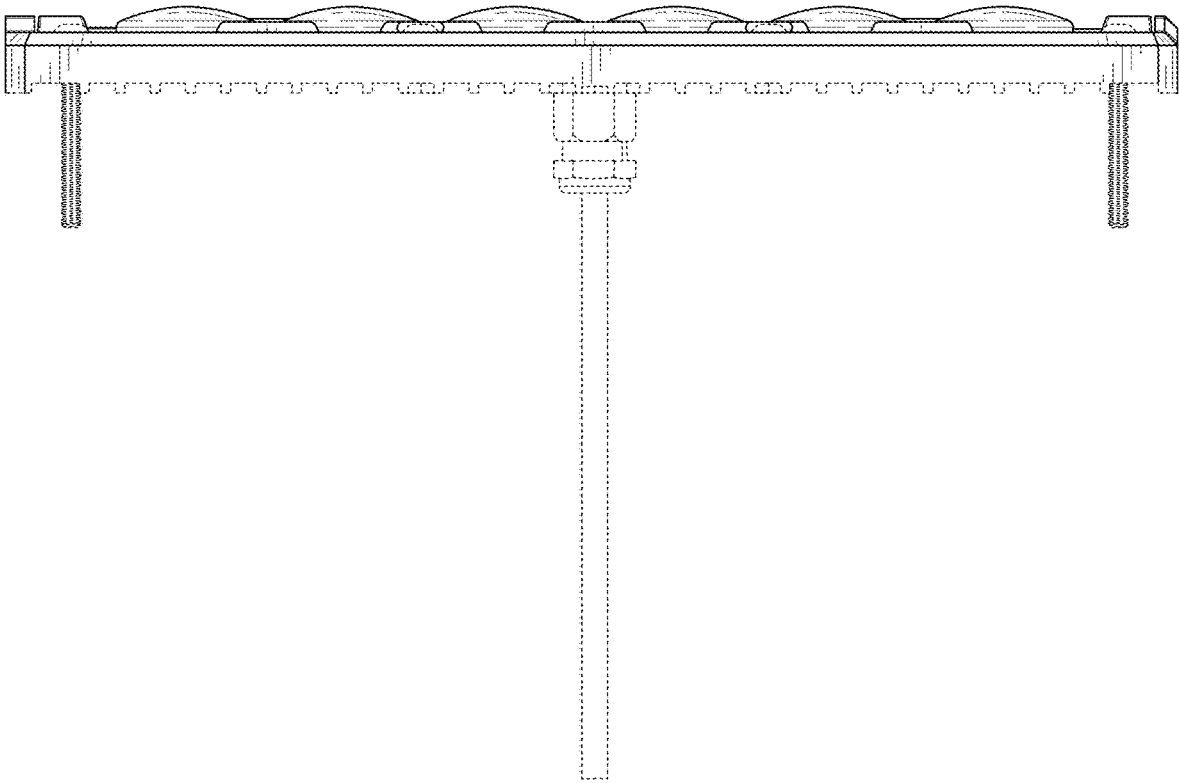

FIG. 3

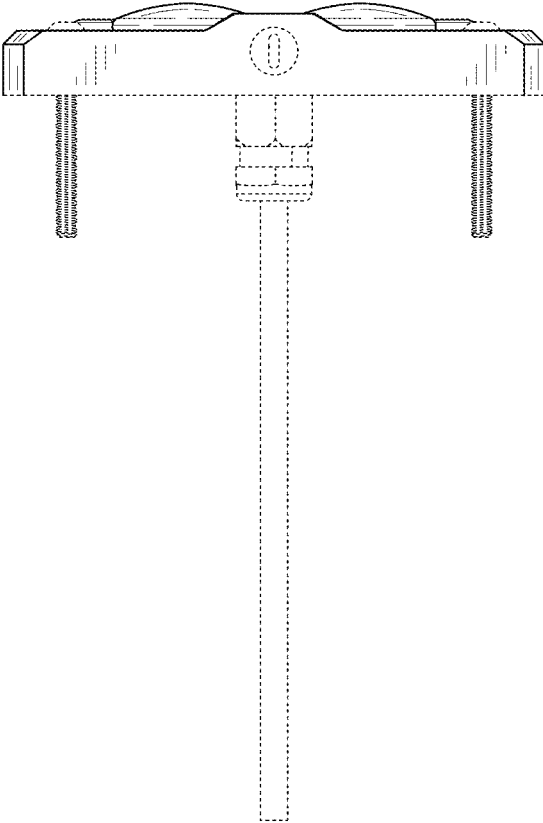

FIG. 4

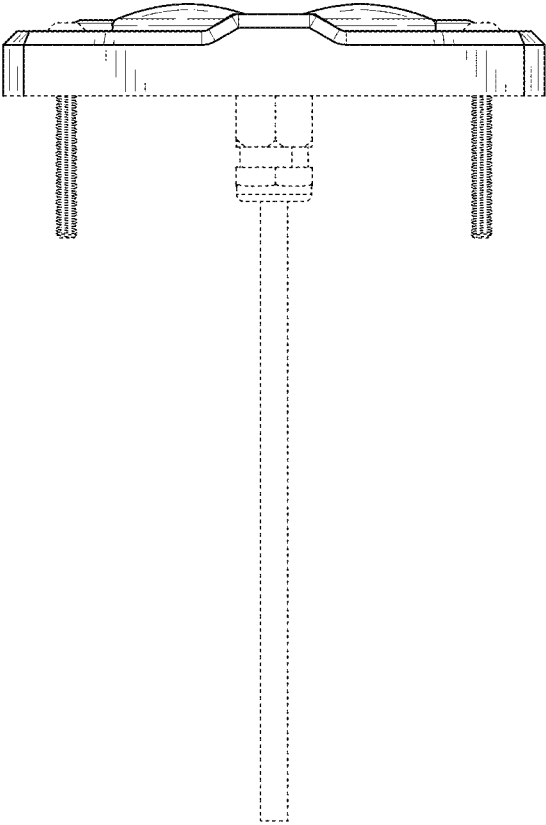

FIG. 5

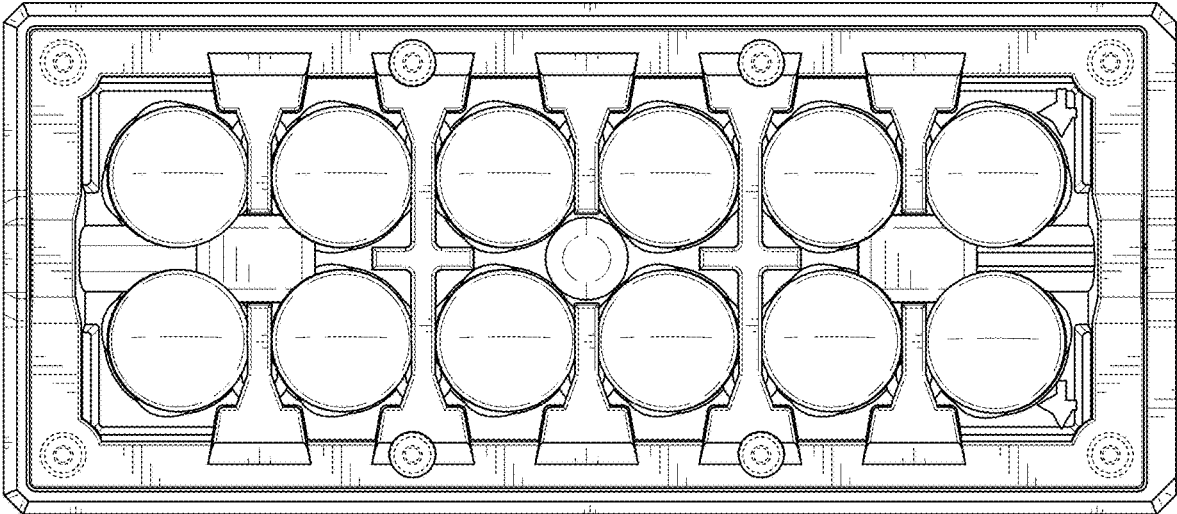

FIG. 6

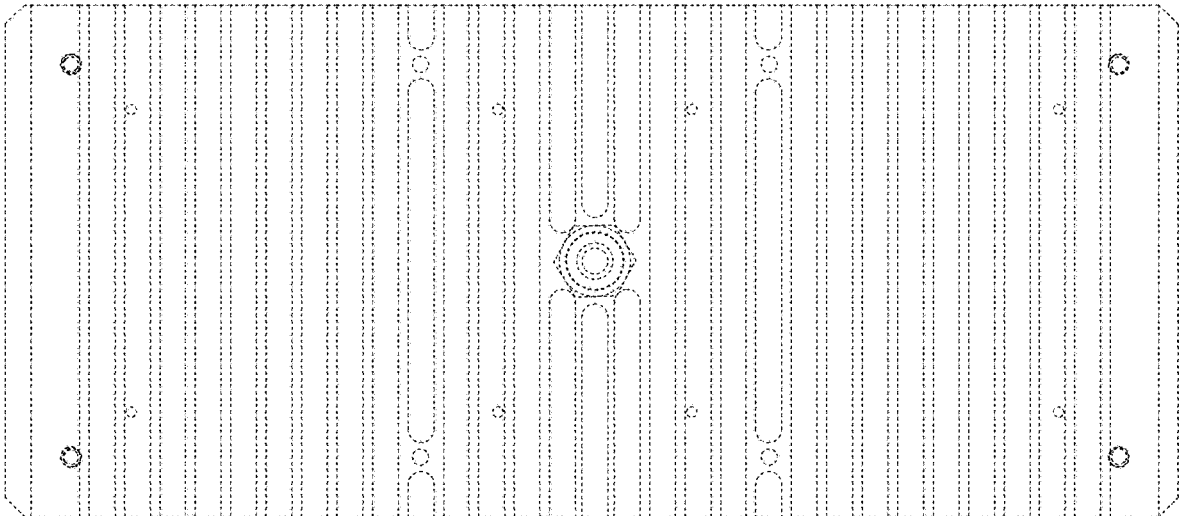

FIG. 7

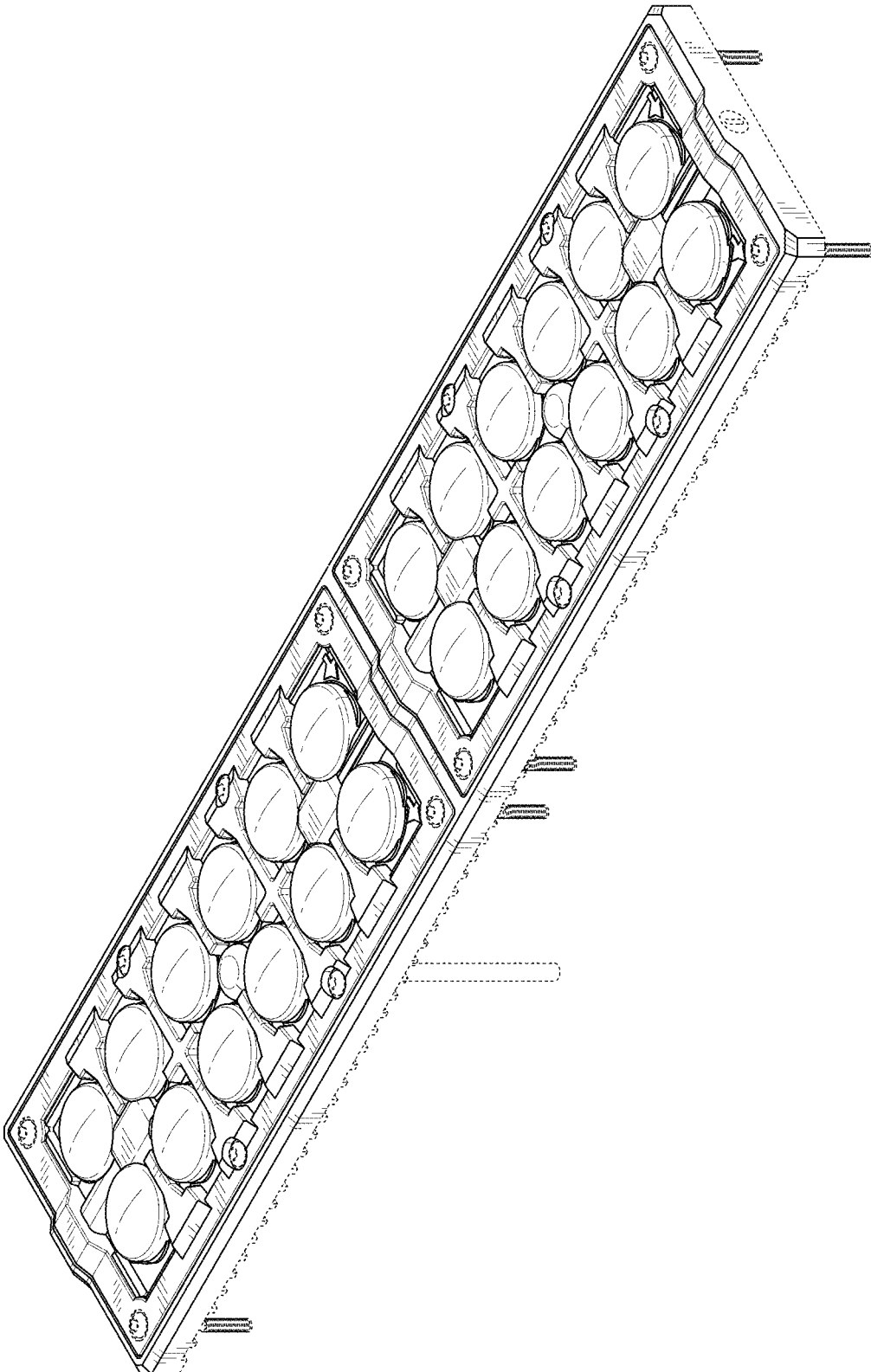

FIG. 8

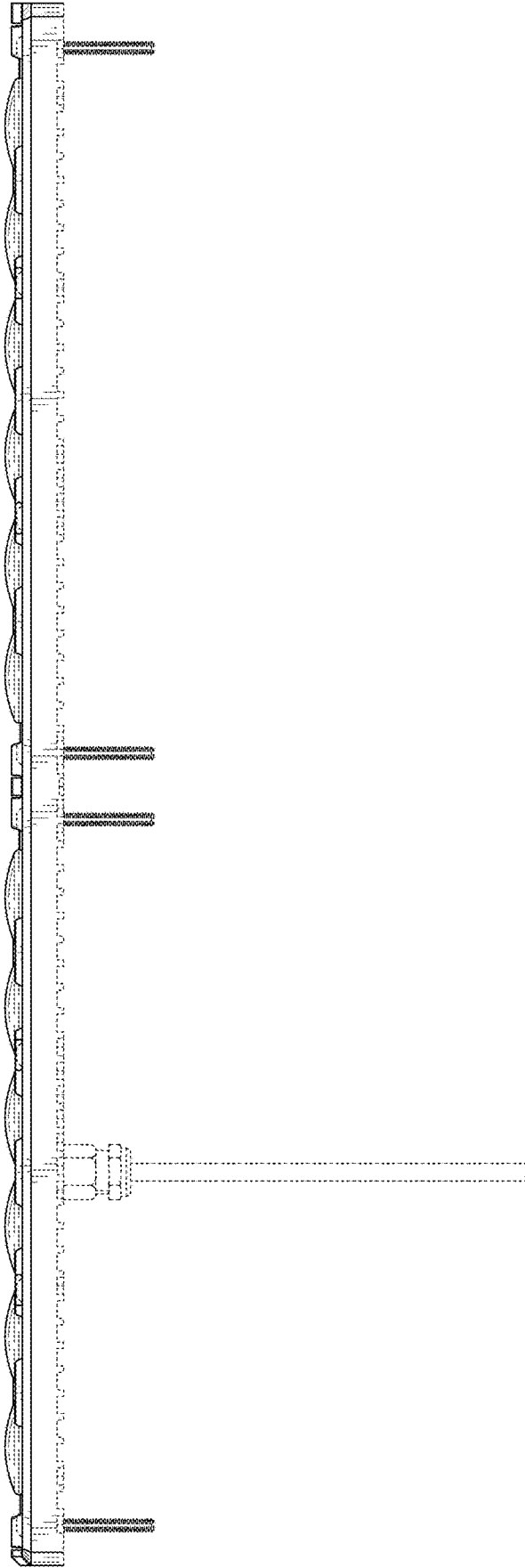

FIG. 9

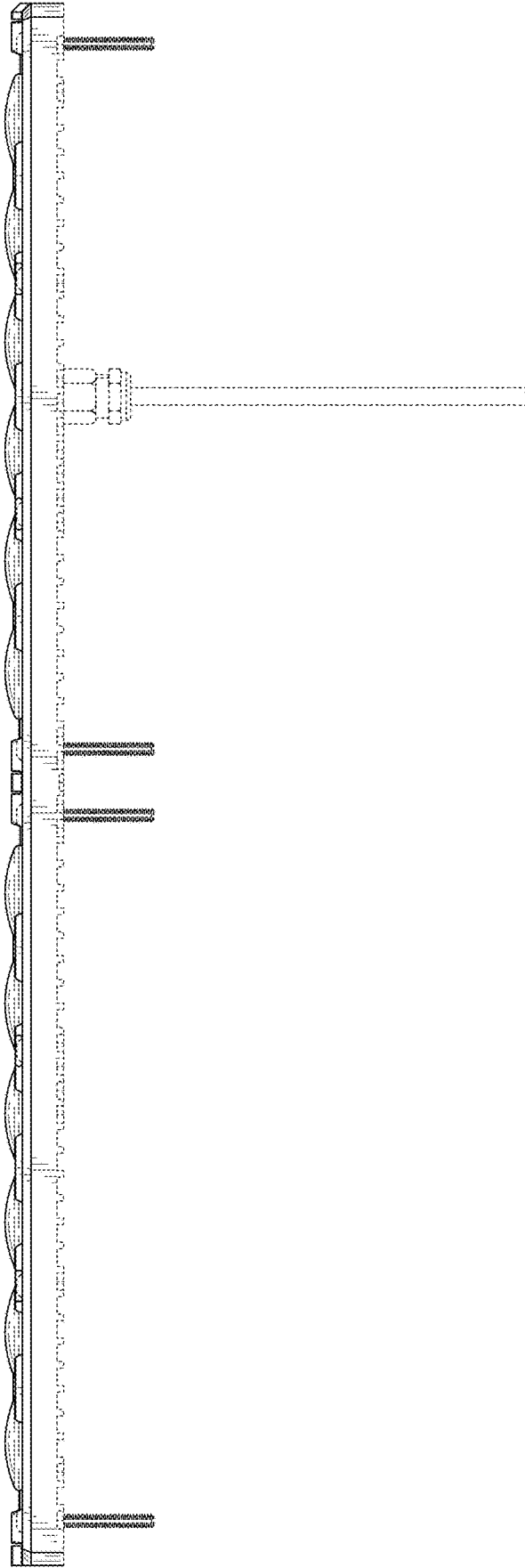

FIG. 10

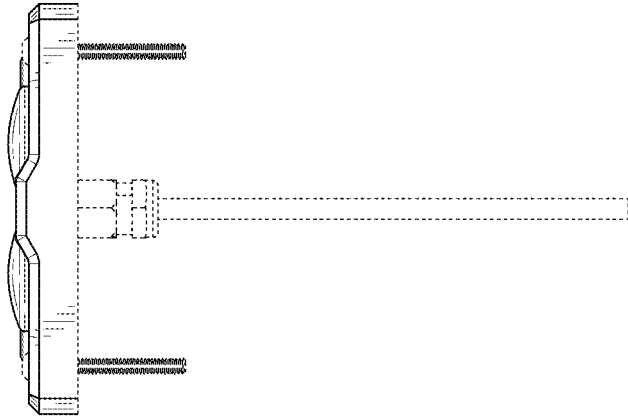

FIG. 11

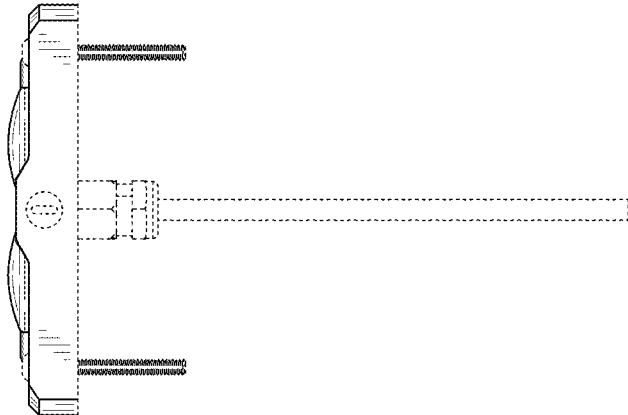

FIG. 12

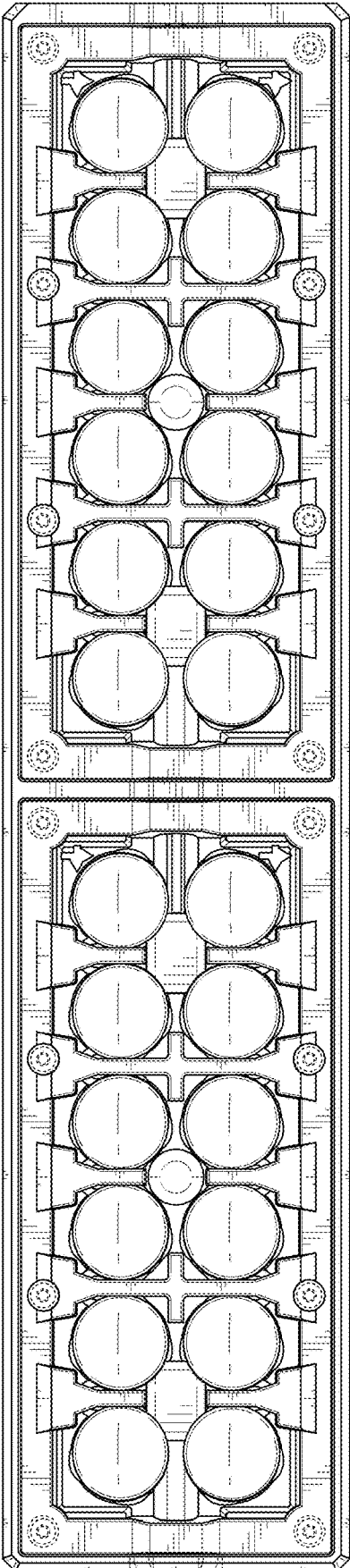

FIG. 13

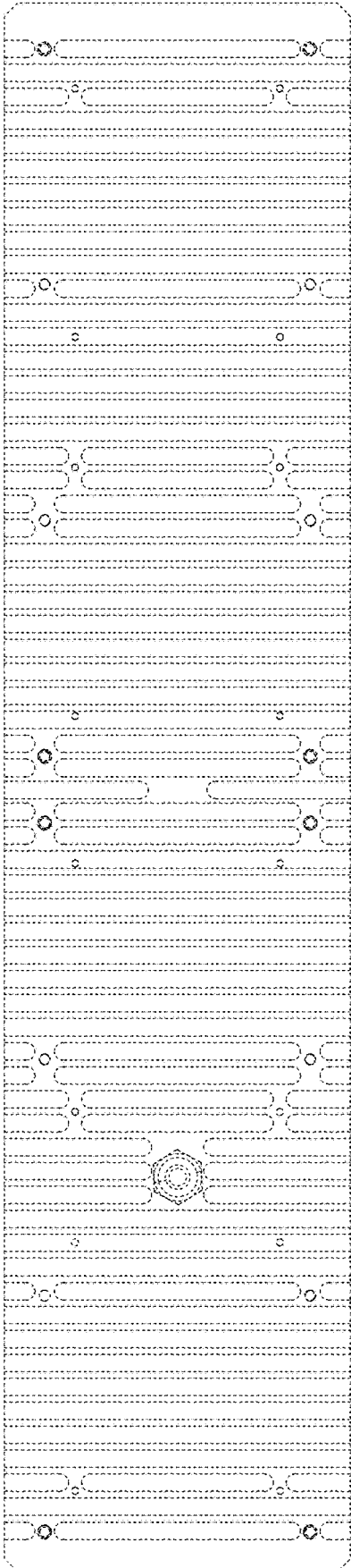

FIG. 14