

**IN THE UNITED STATES DISTRICT COURT  
FOR THE NORTHERN DISTRICT OF ILLINOIS  
EASTERN DIVISION**

JUANREN WU,

Plaintiff,

v.

THE PARTNERSHIPS AND  
UNINCORPORATED ASSOCIATIONS  
IDENTIFIED ON SCHEDULE “A,”

Defendants.

Case No. 26-cv-00358

**Judge Andrea R. Wood**

**Magistrate Judge Beth W. Jantz**

**AMENDED COMPLAINT**

Plaintiff Juanren Wu (“Plaintiff”) hereby brings the present action against the Partnerships and Unincorporated Associations Identified on the Amended Schedule A hereto (hereinafter “Defendants”) and alleges as follows:

**JURISDICTION AND VENUE**

1. This Court has original subject matter jurisdiction over Plaintiff’s claim pursuant to the provisions of the Patent Act, 35 U.S.C. § 1, et seq., 28 U.S.C. § 1338(a), and 28 U.S.C. § 1331.

2. This Court has personal jurisdiction over each Defendant, as Defendants structure their business activities to target consumers in the United States, including Illinois, through at least the fully interactive e-commerce stores operating under the aliases identified on the Amended Schedule A attached hereto. Specifically, Defendants have targeted sales to Illinois residents by setting up and operating e-commerce stores that target United States consumers, offer shipping to the United States, including Illinois, accepts payments in U.S. dollars, and, on information and belief, has sold, and continues to sell counterfeit products that infringe on Plaintiff’s Patent (hereinafter, “Unauthorized Products”) to residents of Illinois.

3. Venue is proper in this Court pursuant to 28 U.S.C. § 1391, since each Defendant directly targets consumers in the United States, including Illinois, through the fully interactive, e-commerce stores operating under the aliases identified on the Amended Schedule A attached hereto (hereinafter, the “Seller Aliases”). Specifically, Defendants have targeted sales to Illinois residents by setting up and operating e-commerce stores that target United States consumers, offer shipping to the United States, including Illinois, accepts payments in U.S. dollars, and, on information and belief, has sold, and continues to sell Unauthorized Products to residents of Illinois. Each of the Defendants is committing tortious acts in Illinois, is engaging in interstate commerce, and has wrongfully caused Plaintiff substantial injury in the state of Illinois.

#### **INTRODUCTION**

4. Plaintiff filed this case to combat the online infringement by Defendants, who trade upon Plaintiff’s valuable patent by making, using, offering for sale, selling and/or importing into the United States for subsequent sale or use the Unauthorized Products. Defendants create e-commerce stores operating under one or more of the Seller Aliases that are making, using, offering for sale, selling and/or importing into the United States for subsequent sale or use the Unauthorized Products to unknowing consumers. E-commerce stores operating under the Seller Aliases share unique identifiers establishing a logical relationship between them, suggesting that Defendants’ operation arises out of the same transaction, occurrence, or series of transactions or occurrences. Defendants take advantage of a set of circumstances including the anonymity and mass reach afforded by the Internet and the cover afforded by international borders to violate Plaintiff’s intellectual property rights with impunity. Defendants attempt to avoid liability by operating under one or more Seller Aliases to conceal their identities, locations, and the full scope and interworking of their operation. Plaintiff is forced to file this action to combat Defendants’ infringement of its registered patent, as well as to protect consumers from purchasing Unauthorized Products over the

internet. Plaintiff has been, and continues to be, irreparably damaged through the infringement of its patent and therefore seeks injunctive and monetary relief.

### **THE PARTIES**

5. Plaintiff, Juanren Wu, is an individual inventor with a passion for creating diamond paintings.

6. Plaintiff is the lawful inventor and patentee of the federally registered design patent, No. US-D1,049,230-S (hereinafter, the “Paint Pen Patent”). The Paint Pen Patent was lawfully issued on October 29, 2024. Attached hereto as **Exhibit 1** is a true and correct copy of the United States Patent for the Diamond Paint Pen design.

7. Plaintiff’s patented design is known throughout the diamond painting community, and thousands of products utilizing Plaintiff’s Paint Pen Patented design (hereinafter, “Plaintiff Products”) have been sold in the United States.

8. Plaintiff Products have become enormously popular, driven by Plaintiff’s quality standards and innovative design. Among the purchasing public, genuine Plaintiff Products are instantly recognizable as such. Plaintiff’s Products symbolize high quality and are among the most recognizable diamond paint pen products.

9. Plaintiff Products are known for their distinctive patented design. The design is broadly recognized by consumers. Diamond paint pens fashioned after these designs are associated with the quality and innovation that the public has come to expect from Plaintiff Products. Plaintiff uses the design claimed in the Paint Pen Patent in connection with its Plaintiff Products. Plaintiff Products, including those which embody the design claimed in the Paint Pen Patent, are marked in compliance with 35 U.S.C. § 287(a).

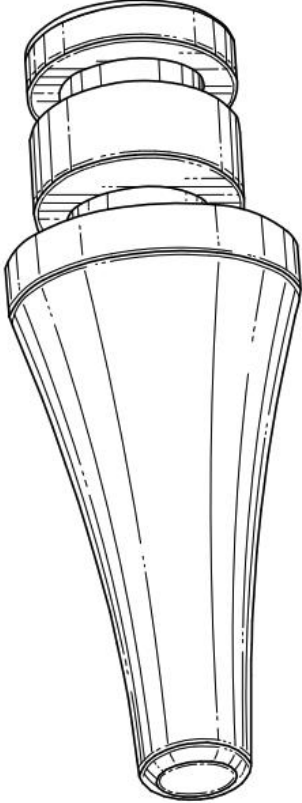
<b>Patent Number</b>	<b>Claim</b>	<b>Issue Date</b>
US-D1,049,230-S		October 29, 2024

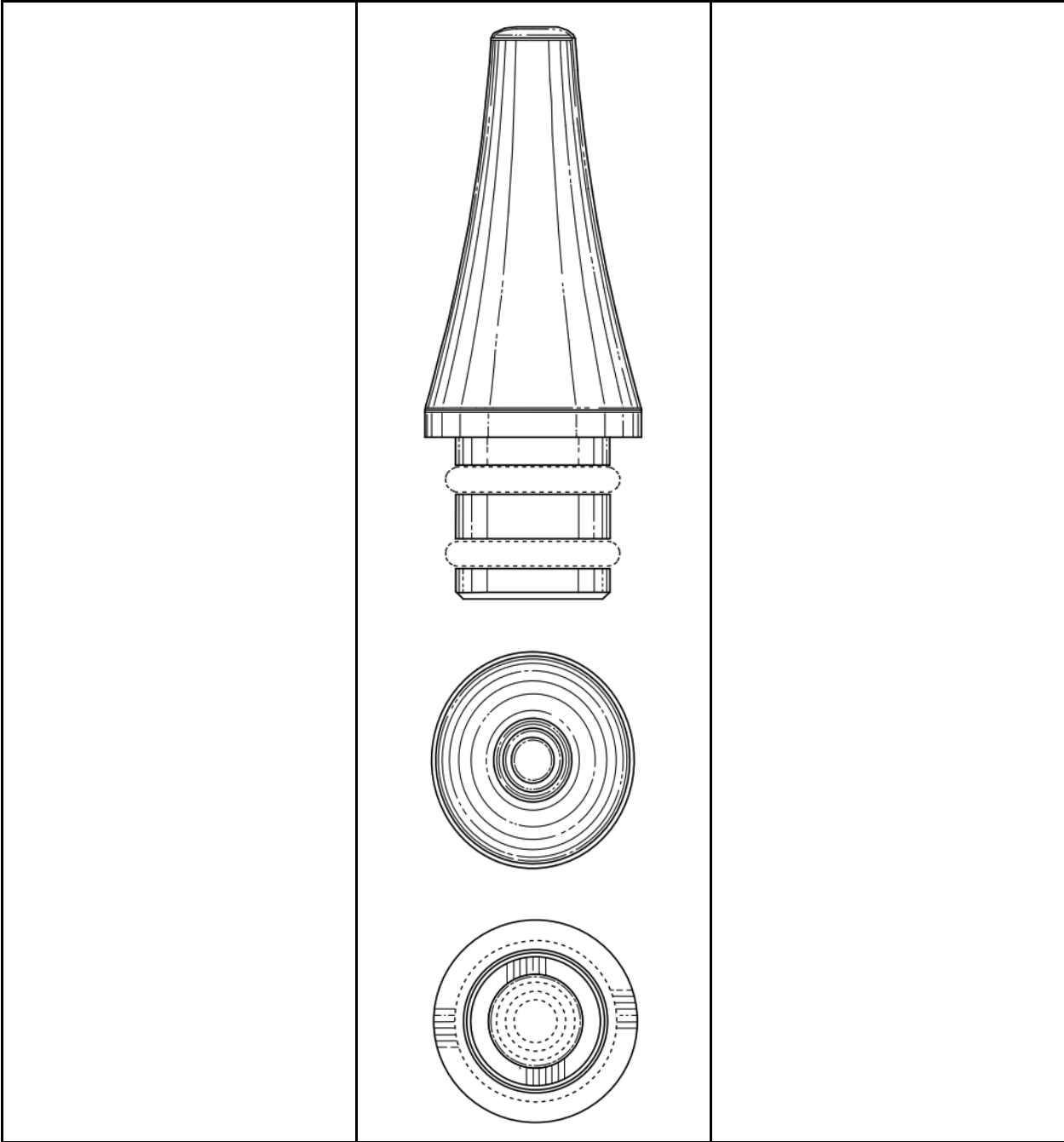

10. Defendants are individuals and business entities of unknown makeup who own and/or operate one or more of the e-commerce stores under at least the Seller Aliases identified on the Amended Schedule A and/or other seller aliases not yet known to Plaintiff.

11. Plaintiff is currently unaware of the identity and/or location of Defendants. However, on information and belief, Defendants are individuals and business entities who reside in China or another foreign jurisdiction. Defendants conduct business throughout the United States, including within Illinois and in this Judicial District, through the operation of the fully interactive commercial websites and online marketplaces operating under the Seller Aliases.

12. Each Defendant targets the United States, including Illinois, and has offered to sell and/or has sold and/or continues to sell Unauthorized Products to consumers within the United States, including Illinois and in this Judicial District.

13. Each Defendant, without any authorization or license from Plaintiff, has knowingly and willfully made, used, offered for sale, sold, and/or imported into the United States for subsequent sale or use the Unauthorized Products.

14. Each of the Defendant's online stores offers shipping and has shipped Unauthorized Products to the United States, including Illinois.

15. On information and belief, Defendants, either individually or jointly, operate one or more e-commerce stores, including, and possibly not limited to, those listed in the Amended Schedule A attached hereto. Tactics used by Defendants to conceal their identities and the full scope of their operation make it virtually impossible for Plaintiff to learn Defendants' true identities and the exact interworking of their network. If Defendants provide additional credible information regarding their identities, Plaintiff will take appropriate steps to amend the Complaint.

#### **DEFENDANTS' UNLAWFUL CONDUCT**

16. The success of products utilizing the Paint Pen Patent design has resulted in significant infringement of the Paint Pen Patent. As a result, Plaintiff has implemented a brand protection program by investigating suspicious websites and online marketplace listings identified in Internet sweeps. In recent years, Plaintiff has identified numerous fully interactive, e-commerce

stores, including those operating under the Seller Aliases, which were offering for sale and/or selling Unauthorized Products on online marketplace platforms such as Amazon, including the e-commerce stores operating under the Seller Aliases. The Seller Aliases target consumers in this Judicial District and throughout the United States. According to a U.S. Customs and Border Protection (“CBP”) Report, in 2024, CBP made over 32 million seizures of goods with intellectual property rights (“IPR”) violations, totaling over \$5.42 billion, an increase of 95% from 2023. See **Exhibit 2**, *Intellectual Property Rights Seizure Statistics, Fiscal Year 2021*, U.S. Customs and Border Protection. “The vast majority of IPR seizures continue to take place within the express consignment and mail shipping methods.” *Id.* Over 90% of all CBP intellectual property seizures originated from mainland China and Hong Kong. *Id.*

17. Defendants have targeted sales to Illinois residents by setting up and operating e-commerce stores that target United States consumers using one or more Seller Aliases, offer shipping to the United States, including Illinois, accept payment in U.S. dollars and/or funds from U.S. bank accounts, and, on information and belief, have sold Unauthorized Products to residents of Illinois.

18. Third party service providers like those used by Defendants do not adequately subject new sellers to verification and confirmation of their identities, allowing infringers to “routinely use false or inaccurate names and addresses when registering with these e-commerce platforms.” See **Exhibit 3**, Daniel C.K. Chow, *Alibaba, Amazon, and Counterfeiting in the Age of the Internet*, 40 NW. J. INT’L L. & BUS. 157, 186 (2020). Further, infringers hedge against the risk of being caught and having their websites taken down from an e-commerce platform by establishing multiple virtual storefronts. See **Exhibit 4**, report on “Combating Trafficking in Counterfeit and Pirated Goods” prepared by the U.S. Department of Homeland Security’s Office

of Strategy, Policy, and Plans (Jan. 24, 2020). Since platforms generally do not require a seller on a third-party marketplace to identify the underlying business entity, infringers can have many different profiles that can appear unrelated even though they are commonly owned and operated. *Id.* at p. 39. Further, “[e]-commerce platforms create bureaucratic or technical hurdles in helping brand owners to locate or identify sources of [infringing products] and [infringers].” Chow, at 186-187.

19. E-commerce store operators like Defendants commonly engage in fraudulent conduct when registering the Seller Aliases by providing false, misleading, and/or incomplete information to e-commerce platforms to prevent discovery of their true identities and the scope of their e-commerce operation.

20. E-commerce store operators like Defendants regularly register or acquire new seller aliases for the purpose of offering for sale and selling Unauthorized Products. Such seller alias registration patterns are one of many common tactics used by e-commerce store operators like Defendants to conceal their identities and the full scope and interworking of their operation, and to avoid being shut down.

21. Even though Defendants operate under multiple fictitious aliases, the e-commerce stores operating under the Seller Aliases often share unique identifiers, such as templates with common design elements that intentionally omit any contact information or other information for identifying Defendants or other Seller Aliases they operate or use. E-commerce stores operating under the Seller Aliases include other notable common features, such as use of the same registration patterns, accepted payment methods, check-out methods, keywords, advertising tactics, similarities in price and quantities, the same incorrect grammar and misspellings, and/or the use of the same text and images. Additionally, Unauthorized Products offered for sale by the

Seller Aliases bear similar irregularities and indicia of being unauthorized to one another, suggesting that the Unauthorized Products were manufactured by and come from a common source and that Defendants are interrelated.

22. Infringers such as Defendants typically operate under multiple seller aliases and payment accounts so that they can continue operation in spite of Plaintiff's enforcement. E-commerce store operators like Defendants maintain offshore bank accounts and regularly move funds from their financial accounts to offshore accounts outside the jurisdiction of this Court to avoid payment of any monetary judgment awarded to Plaintiff.

23. On information and belief, Defendants have engaged in fraudulent conduct when registering the Defendant Internet Stores by providing false, misleading and/or incomplete information to Internet based e-commerce platforms. On information and belief, certain Defendants have anonymously registered and maintained Defendant Internet Stores to prevent discovery of their true identities and the scope of their infringement network.

24. On information and belief, Defendants regularly register or acquire new seller aliases for the purpose of offering for sale and selling the Infringing Products. Such seller alias registration patterns are one of many common tactics used by the Defendants to conceal their identities and the full scope and interworking of their infringement operation, and to avoid being shut down.

25. Even though Defendants operate under multiple fictitious aliases, the e-commerce stores operating as the Defendant Internet Stores often share unique identifiers, such as templates with common design elements. E-commerce stores operating as the Defendant Internet Stores, or other currently unknown aliases, include other notable common features such as use of the same registration patterns, accepted payment methods, check-out methods, keywords, illegitimate

search engine optimization (SEO), advertising tactics, the same incorrect grammar and misspellings, and/or the use of the same text and images. Additionally, the offers for sale and advertisements by the Defendant Internet Stores bear similar irregularities and indicia of being related to one another, suggesting that the Defendants are interrelated.

26. On information and belief, Defendants are in constant communication with each other and regularly participate in QQ.com and WeChat chat rooms regarding tactics for operating multiple accounts, evading detection, pending litigation, and potential new lawsuits.

27. Infringers such as Defendants typically operate under multiple seller aliases and payment accounts so that they can continue operation in spite of Plaintiff's enforcement efforts. On information and belief, Defendants maintain offshore bank accounts and regularly move funds from their financial accounts to offshore accounts outside the jurisdiction of this Court to avoid payment of any monetary judgment awarded to Plaintiff. Indeed, analysis of financial transaction logs from previous similar cases indicates that offshore infringers regularly move funds from U.S.-based financial accounts to offshore accounts outside the jurisdiction of this Court.

28. Defendants are collectively causing harm to Plaintiff's goodwill and reputation because the effect of their unlawful actions taken together amplifies each harm and creates a single negative consumer impression. Defendants' activities, occurring at the same time and in the same retail space and manner as one another, blend together to create a single negative impression on consumers such that they constitute the same occurrence or series of occurrences. The combination of all Defendants engaging in the same illegal activity in the same time span causes a collective harm to Plaintiff in a way that individual actions, occurring alone, might not.

29. On information and belief, Defendants are working in active concert to knowingly and willfully import, distribute, offer for sale, and sell Unauthorized Products in the same

transaction, occurrence, or series of transactions or occurrences. Defendants, without any authorization or license from Plaintiff have knowingly and willfully offered for sale, sold, and/or imported into the United States for subsequent resale or use the same product that infringes directly and/or indirectly the Paint Pen Patent. Each e-commerce store operating under the Seller Aliases offers shipping to the United States, including Illinois, and, on information and belief, each Defendant has sold and shipped Unauthorized Products into the United States and Illinois over the Internet.

30. Defendants' infringement of the Paint Pen Patent in connection with the making, using, offering for sale, selling, and/or importing into the United States for subsequent sale or use of the Unauthorized Products, including the making, using, offering for sale, selling, and/or importing into the United States for subsequent sale or use of Unauthorized Products into Illinois, is irreparably harming Plaintiff.

31. In sum, Plaintiff's investigation shows that the telltale signs of an illegal infringement ring or common ownership are present in the instant action based upon the use of generic stock images and inventory. Upon receipt of additional information identifying related stores unknown to Plaintiff at this time, Plaintiff will amend its Complaint.

**COUNT I**  
**DESIGN PATENT INFRINGEMENT (35 U.S.C. § 271)**

32. Plaintiff hereby re-alleges and incorporates by reference the allegations set forth in paragraphs 1-30 as if fully set forth herein.

33. Plaintiff is the lawful patentee of the Paint Pen Patent.

34. Defendants are making, using, offering for sale, selling, and/or importing into the United States for subsequent sale or use the Unauthorized Products that infringe directly and/or through the doctrine of equivalents the ornamental design claimed in the Paint Pen Patent.

35. Defendants have infringed the Paint Pen Patent through the aforementioned acts and will continue to do so unless enjoined by this Court. Defendants' wrongful conduct has caused Plaintiff to suffer irreparable harm resulting from the loss of its lawful patent rights to exclude others from making, using, selling, offering for sale, and importing the patented invention.

36. Plaintiff is entitled to injunctive relief pursuant to 35 U.S.C. § 283.

37. Plaintiff is entitled to recover damages adequate to compensate for the infringement, including Defendants' profits pursuant to 35 U.S.C. § 289. Plaintiff is entitled to recover any other damages as appropriate pursuant to 35 U.S.C. § 284.

#### **PRAYER FOR RELIEF**

WHEREFORE, Plaintiff requests judgment against Defendants as follows:

- 1) That Defendants, their affiliates, officers, agents, servants, employees, attorneys, confederates, and all persons acting for, with, by, through, under or in active concert with them be permanently enjoined and restrained from:
  - a) making, using, offering for sale, selling, and/or importing into the United States for subsequent sale or use the Unauthorized Products;
  - b) aiding, abetting, contributing to, or otherwise assisting anyone in making, using, offering for sale, selling, and or importing into the United States for subsequent sale or use the Unauthorized Products; and
  - c) Effecting assignments or transfers, forming new entities or associations or utilizing any other device for the purpose of circumventing or otherwise avoiding the prohibitions set forth in Subparagraphs (a) and (b).
- 2) For Judgment in favor of Plaintiff against Defendants that they have willfully infringed Plaintiff's rights in its Paint Pen Patent, pursuant to 35 U.S.C. § 271.

- 3) That Plaintiff be awarded such damages as it shall prove at trial against Defendants that are adequate to compensate Plaintiff for Defendants' infringement of the Paint Pen Patent, but in no event less than a reasonable royalty for the use made of the invention by Defendants, together with interests and costs, pursuant to 35 U.S.C. § 284.
- 4) That the amount of damages awarded to Plaintiff to compensate Plaintiff for infringement of the Paint Pen Patent be increased by three times the amount thereof, as provided by 35 U.S.C. § 284.
- 5) In the alternative, that Plaintiff be awarded all profits realized by Defendants from Defendants' infringement of the Paint Pen Patent, pursuant to 35 U.S.C. § 289.
- 6) That Plaintiff be awarded its reasonable attorneys' fees and costs; and
- 7) Award any and all other relief that this Court deems just and proper.

Respectfully Submitted this 3rd day of February 2026.

*/s/ William Hausman*  
William Hausman  
Bar No. 6353083  
Ford Banister LLC  
305 Broadway - Floor 7  
New York NY 10007  
Telephone: +1 (212) 500-3268  
Fax: +1 (212) 500-3269  
Email:whausman@fordbanister.com  
*Attorney for Plaintiff*